



RECHARGEABLE HEADLIGHT

# VOLT 6000™

HL-EL6000RC



**Manual**

Design Pat. Pending  
Copyright© 2017 CATEYE Co., Ltd.  
HLEL6000RC-170720 9



# COMPONENTS



Light unit

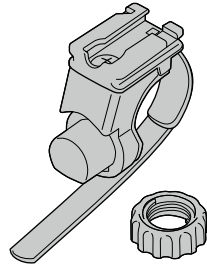

FlexTight™ bracket  
(H-34N HP)

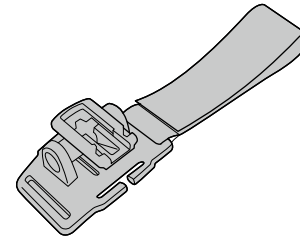

Helmet mount  
(Helmet mount HP)

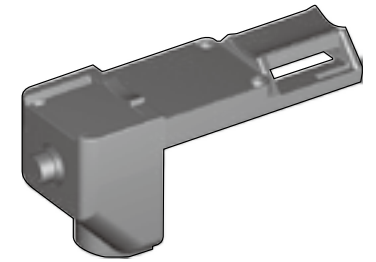

Control unit

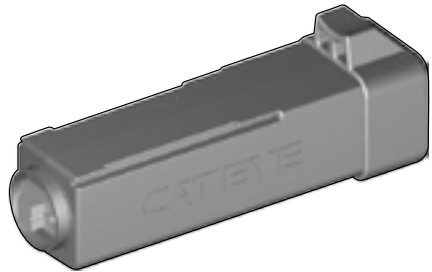

Battery unit  
(BA-608)

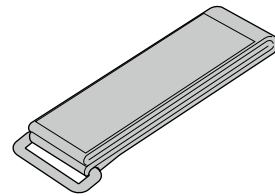

Fixing strap

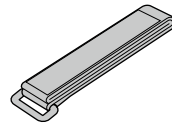

Auxiliary strap



Extension cable

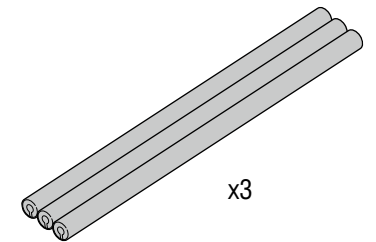

Cable cover  
x3



Remote control switch  
(WSW-001)

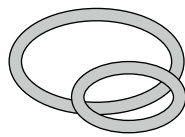

Rubber band (Large/Small)

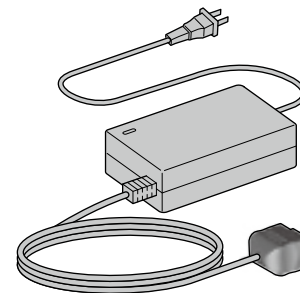

Battery charger

# ! PRECAUTIONS ON USE

Frequency Band: 2.4 GHz Radiated Power: 83.46 dBuV/m (at 3 m)  
Hereby, CATEYE Co., Ltd. declares that the radio equipment type HL-EL6000RC is in compliance with Directive 2014/53/EU.  
The full text of the EU declaration of conformity is available at the following internet address:  
cateye.com/doc

This device complies with Part 15 of the FCC Rules and Industry Canada licence-exempt RSS standard(s). Operation is subject to the following two conditions: (1) this device may not cause harmful interference, and (2) this device must accept any interference received, including interference that may cause undesired operation.

*Le présent appareil est conforme à la réglementation FCC, partie 15, et aux CNR d'Industrie Canada applicables aux appareils radio exempts de licence. L'exploitation est autorisée aux deux conditions suivantes:*

- 1. l'appareil ne doit pas produire de brouillage;*
- 2. l'utilisateur de l'appareil doit accepter tout brouillage radioélectrique subi, même si le brouillage est susceptible d'en compromettre le fonctionnement.*

**Modifications** The FCC requires the user to be notified that any changes or modifications made to this device that are not expressly approved by CatEye Co., Ltd. may void the user's authority to operate the equipment.

**NOTE:** This equipment has been tested and found to comply with the limits for a Class B digital device, pursuant to Part 15 of the FCC Rules. These limits are designed to provide reasonable protection against harmful interference in a residential installation. This equipment generates, uses and can radiate radio frequency energy and, if not installed and used in accordance with the instructions, may cause harmful interference to radio communications. However, there is no guarantee that interference will not occur in a particular installation. If this equipment does cause harmful interference to radio or television reception, which can be determined by turning the equipment off and on, the user is encouraged to try to correct the interference by one or more of the following measures:

Reorient or relocate the receiving antenna.

Increase the separation between the equipment and receiver.

Connect the equipment into an outlet on a circuit different from that to which the receiver is connected.

Consult the dealer or an experienced radio/TV technician for help.

This Class B digital apparatus complies with Canadian ICES-003.

*Cet appareil numérique de la classe B est conforme à la norme NMB-003 du Canada.*

**Do not use this light on public roads. The VOLT 6000 is an extremely high power light with a very wide beam angle.**

**As such, it may distract oncoming drivers, which is extremely dangerous. If you have no choice but to use this light on public roads, be sure to use it in low mode / all night mode.**

- **Never short-circuit the terminals of the battery unit or the battery charger. It may cause the unit to overheat, resulting in fire or damage to the component.**
- **The battery unit uses lithium batteries. If liquid leaks from the batteries, do not touch them with bare hands and do not bring them close to fire.**
- **Securely connect the plug and fasten the strap. Otherwise, they may come off while riding, causing the light to turn off, or you could topple over if the cable gets caught in the wheel.**
- **Never use this product with a damaged cord or fixing strap. Instead, contact CATEYE customer service for repairs.**
- **Do not stare at the light when it is on. Doing so may damage your eyesight.**
- **Do not place it within children's reach.**
- **Do not disassemble the light unit, control unit, battery unit, or battery charger.**
- **Do not insert foreign substances into the light's cooling fan. If the fan stops, the temperature will increase. As a result, the safety circuit will activate, and the lighting mode will be decreased by a level.**
- **Do not store the battery unit in a car or near a heater. Charging, discharging and storing at high temperature may accelerate battery deterioration.**
- **Charge the battery unit prior to use.**
- **Cool and dry storage is recommended. For long period storage, it is important to charge the battery 30 minutes every 6 months.**
- **If the lamp body or parts become dirty with mud, etc., clean with a soft cloth which is moistened with mild detergent then wipe off moisture with a dry cloth. Never apply paint thinner, benzine or alcohol; damage will result.**
- **When the connecting plug is dirty with mud, etc., clean it with the plug connected and locked.**
- **This product is water-resistant under normal daily use and can be used in the rain. However, do not intentionally submerge it in water.**
- **Risk of explosion if undesignated battery is used. Dispose of used batteries according to local regulations.** 
- **Always attention to the remaining battery power by checking the indicator periodically while using.**
- **We recommend carrying a spare light or battery unit with you in case the battery dies unexpectedly.**
- **Mounting the light unit too close to a wireless computer may adversely affect the reading of the computer.**

# PRECAUTIONS ON USE

## Handling the remote control switch

- **The remote control switch and the light have ID-based pairing function in order to eliminate interference with other devices.**  
Although the IDs have been paired at the factory, check that the remote control switch turns on/off the light before use.  
When you replace the remote control switch due to damage or loss, follow the instructions in the operation manual to pair the switch with the light.
- **While the light is in use, do not keep the remote control switch in a pocket, bag, or similar location while traveling.**  
It may cause the switch to be operated by mistake, causing the light to turn off.
- **Pressing and holding the remote control switch will significantly reduce battery life.**

## Storing the light unit

- **Remove the battery unit from the control unit to prevent unintentional illumination of the light during storage.**

## Using the light

- **In Dynamic mode, the headlight can be turned on continuously, but continuous illumination in high temperatures may cause the protection function to activate earlier, causing the lighting mode to be decreased by a level.**
- **Make sure that the lens is clean before use. Using the light with foreign material such as mud on the lens may cause the lens to melt.**

This ultra high intensity light can generate a significant amount of heat during operation and there is a risk of fire or burns. Using the light under the following conditions is dangerous.

- **Do not place hands or any other objects in front of the lens while the light is in use.**
- **Do not use the light with the lens facing downward on any table, wooden, or otherwise potentially flammable surface.**

Please follow these precautions when handling the light.

# HOW TO CHARGE BATTERY UNIT

## PRECAUTIONS ON CHARGING

- If the battery unit is wet, wipe off moisture with a dry cloth before charging the batteries.
  - Be sure to use only the supplied battery charger (applicable to 100 - 240 volts). The battery charger is indoor use only.
  - Do not leave the battery unit for a long time with the battery charged.
  - When the operating time decreases significantly, the battery life is close to an end. Replace the battery unit with a new one.
  - Dispose of used battery units appropriately according to local regulations.
- \* The standard charging time and run time are guideline values and may vary depending on the operating environment.
- \* With the included battery unit BA-608 (6800 mAh), the battery is approximately 80% charged approximately 3 hours after the start of charging.

 Always charge the product before use.

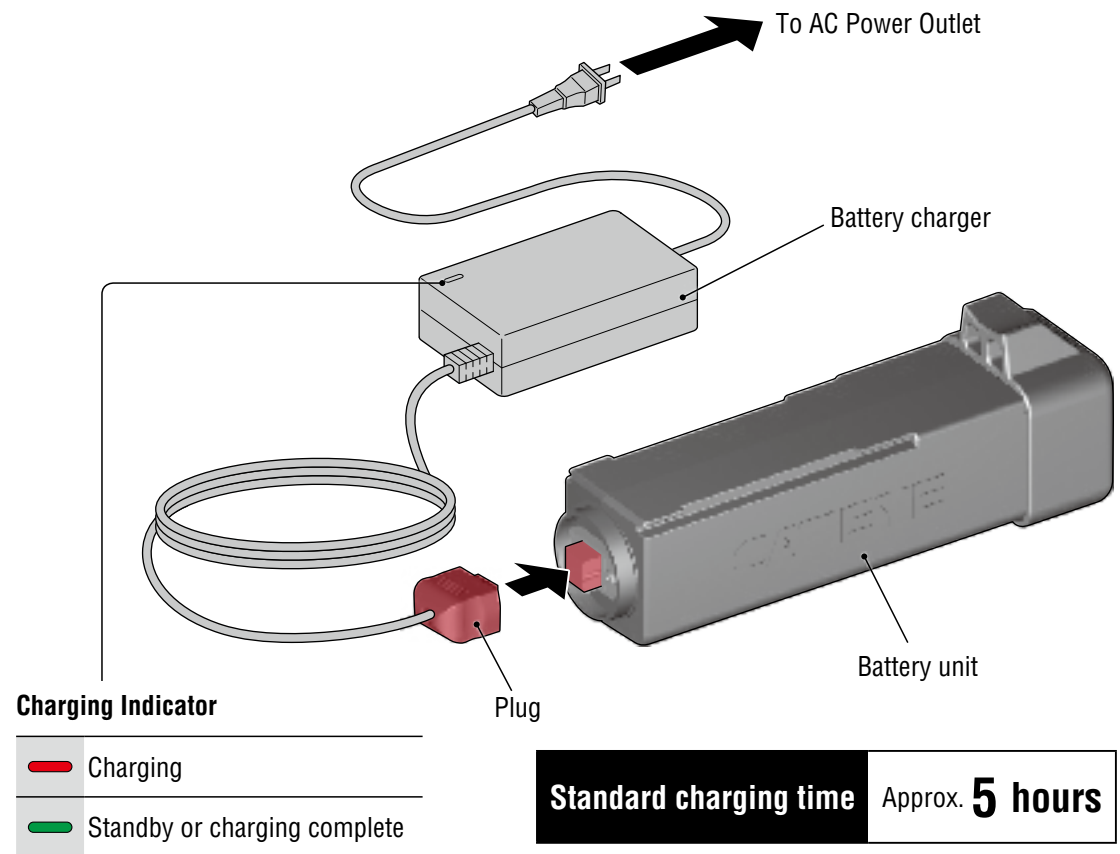

When you insert the battery charger into an outlet, the charging indicator lights up in green. Then, when you connect the plug to the battery unit, the charging indicator lights up in red and charging begins. When the charging indicator lights up in green again, charging is complete.

# HOW TO MOUNT TO A BICYCLE (1/3)

## PRECAUTIONS WHEN MOUNTING

- Be sure to tighten the dial by hand. When you tighten it too hard with a tool, the screw thread may be stripped.
- Round off the cut edge of the bracket strap to prevent injury.
- Ensure that the frame is clean, and then pull the fixing strap tightly to fix the control unit in place. If the control unit is not securely fixed in place, the battery unit may shift or come off due to impacts during riding.
- When some cables are installed along the top tube, attach the cable cover in advance to protect the cable from any force applied. Otherwise, it may cause trouble in braking or gear shifting.
- Pay attention to the arrangement of the cable so that it does not interfere with the handling of the bicycle.  
Do not secure the cable at an acute angle because the wire inside the cable may break.
- Do not use a damaged rubber band.

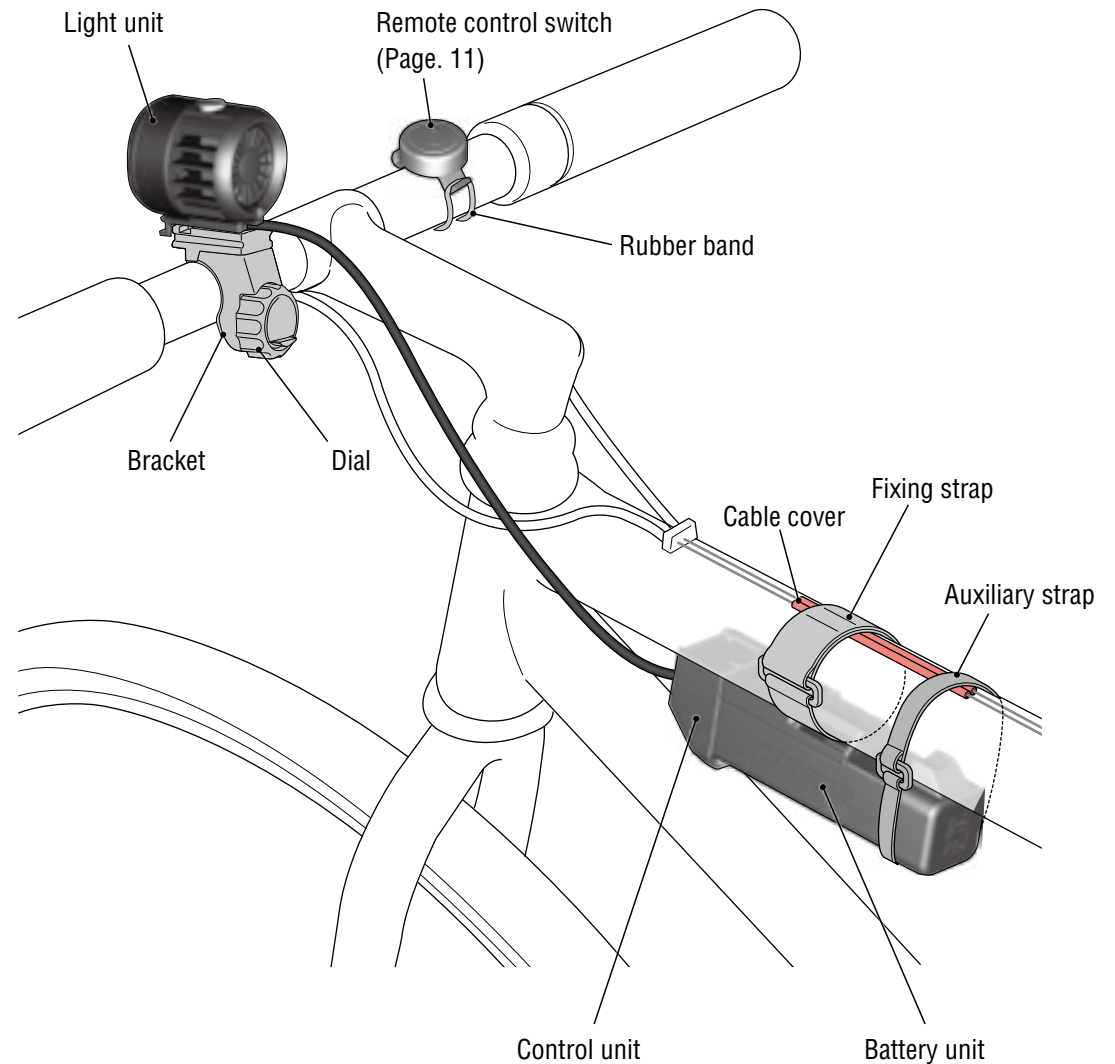



# HOW TO MOUNT TO A BICYCLE (2/3)

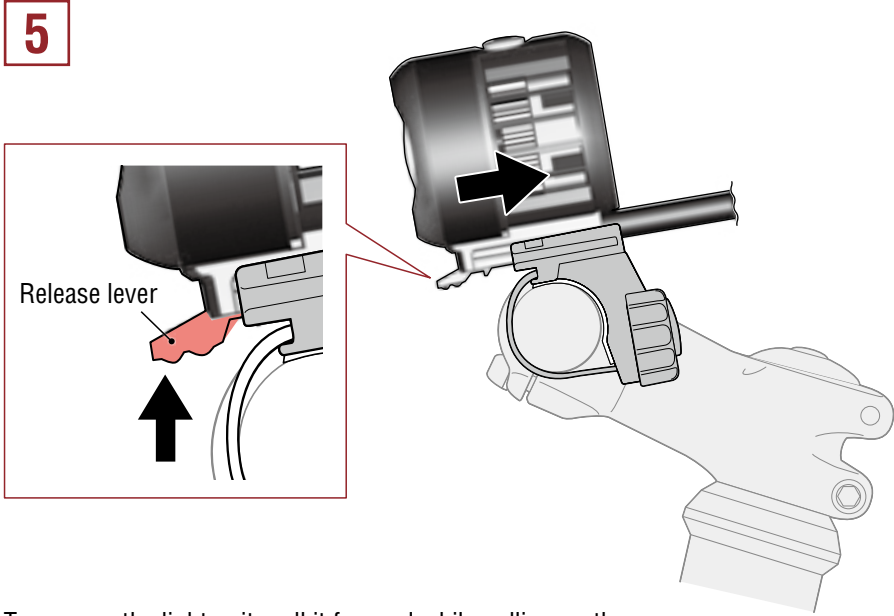
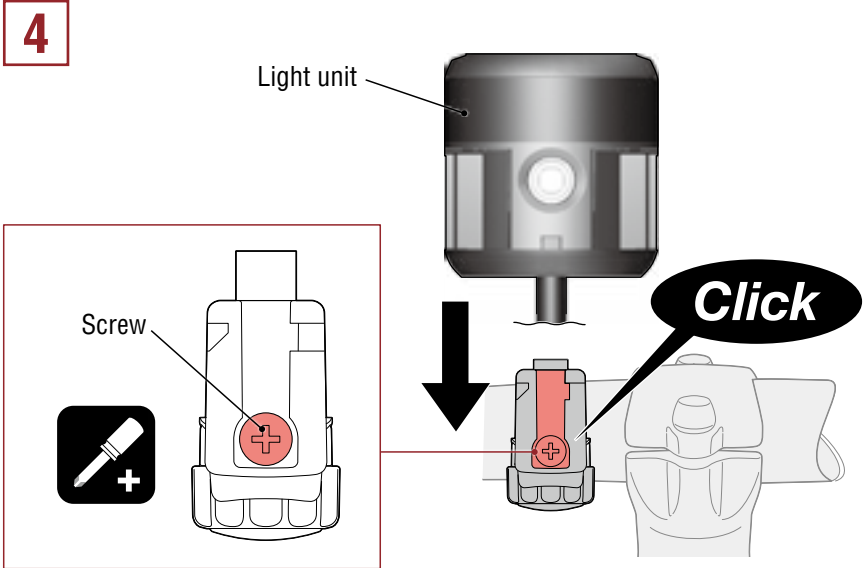
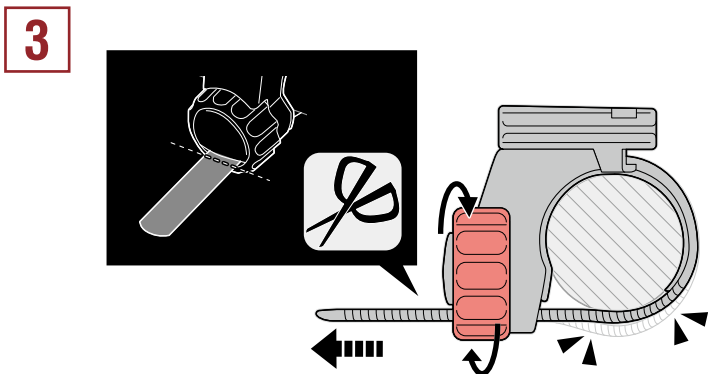
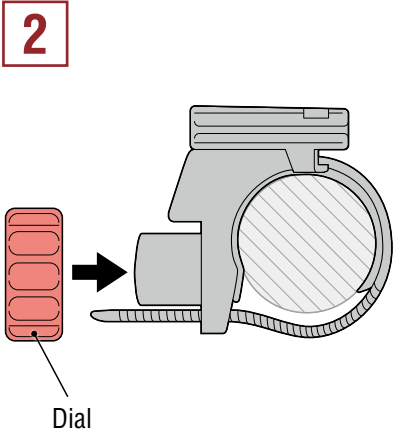
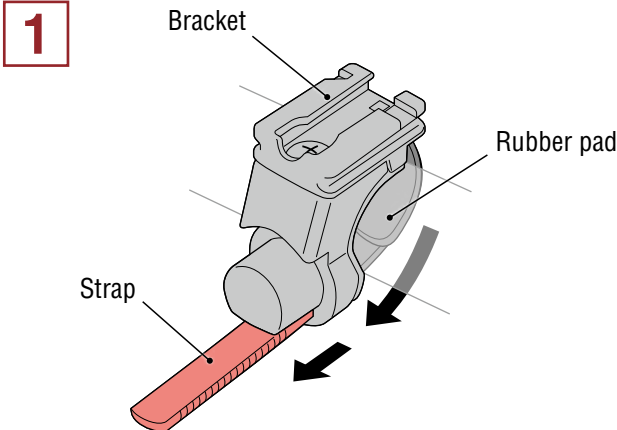

**⚠ CAUTION!** Check the dial and screw on the bracket periodically, and use them without any loosening.

To remove the light unit, pull it forward while pulling up the release lever.

# HOW TO MOUNT TO A BICYCLE (3/3)

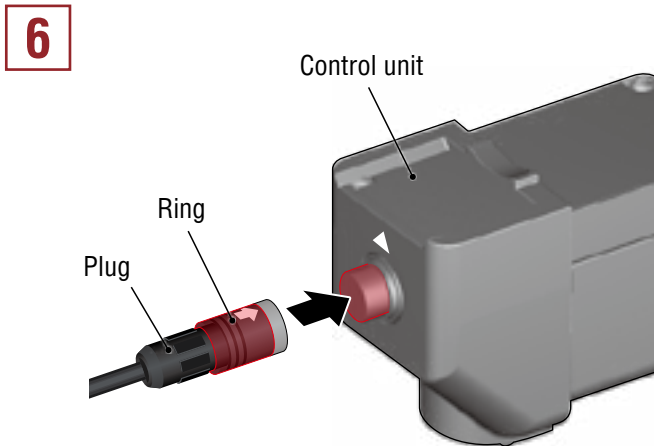

Connect the plug so that the directions of the arrow and the ▲ mark match. To remove the plug, hold the ring, and then pull out the plug.

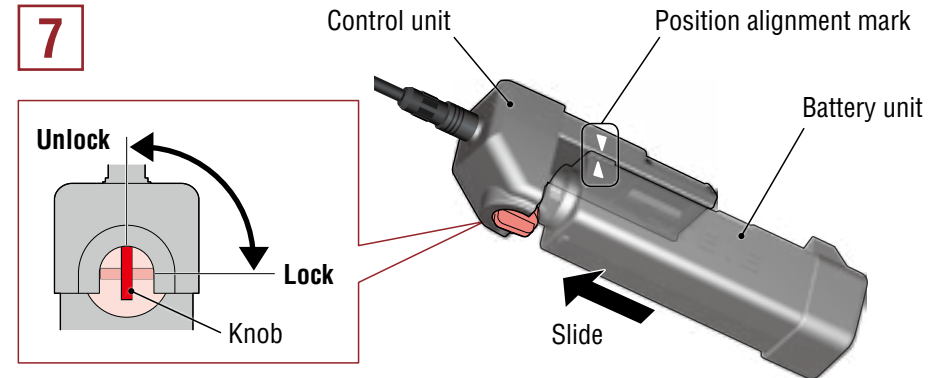

Set the knob of the control unit to the “Unlock” position, align the battery unit with the position alignment mark, and then slide the battery unit into place.

**⚠ CAUTION!:** After you connect the battery unit, be sure to set the knob back to the “Lock” position to lock the battery unit in place.

To remove the battery unit, set the knob to the “Unlock” position, and then pull out the battery unit.

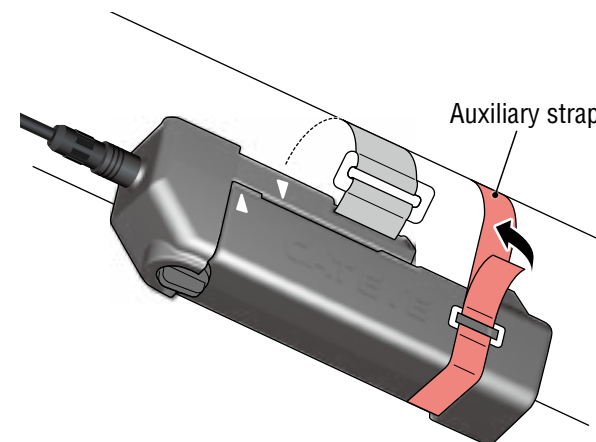
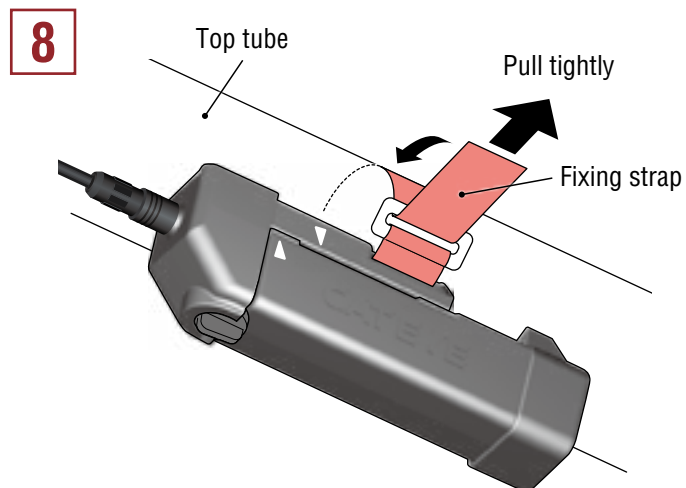

\* Use the auxiliary strap to firmly secure the battery unit.



# MOUNTING THE LIGHT UNIT ON A HELMET

(1/3)

## ! How to handle the battery unit

Carry the battery unit in a pocket or bag, with the rubber pad removed. Before doing that, be sure that the cable of the battery unit is properly accommodated.

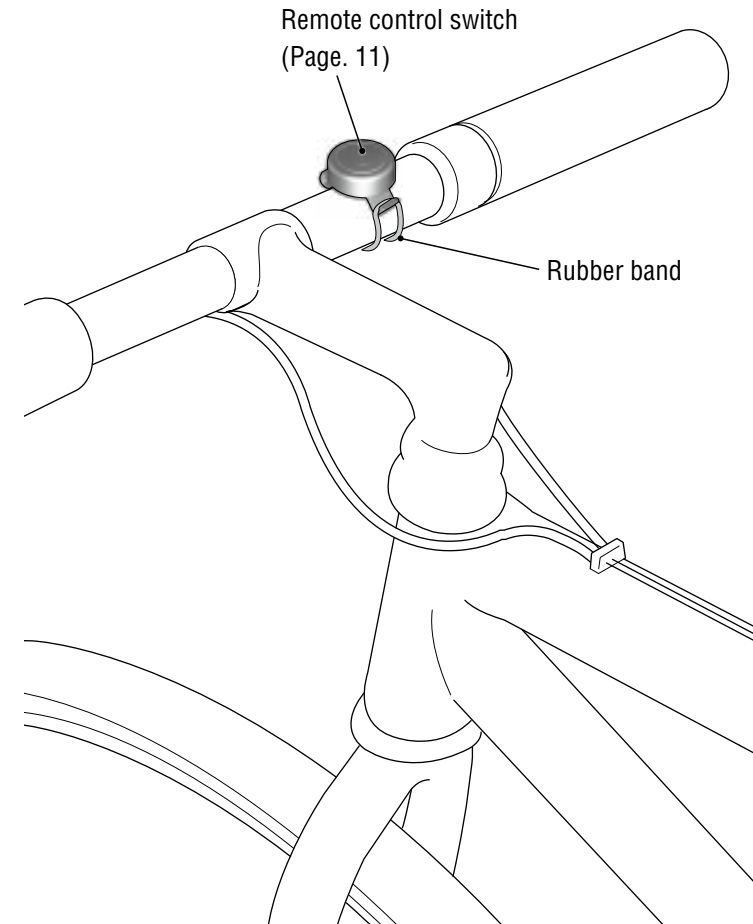
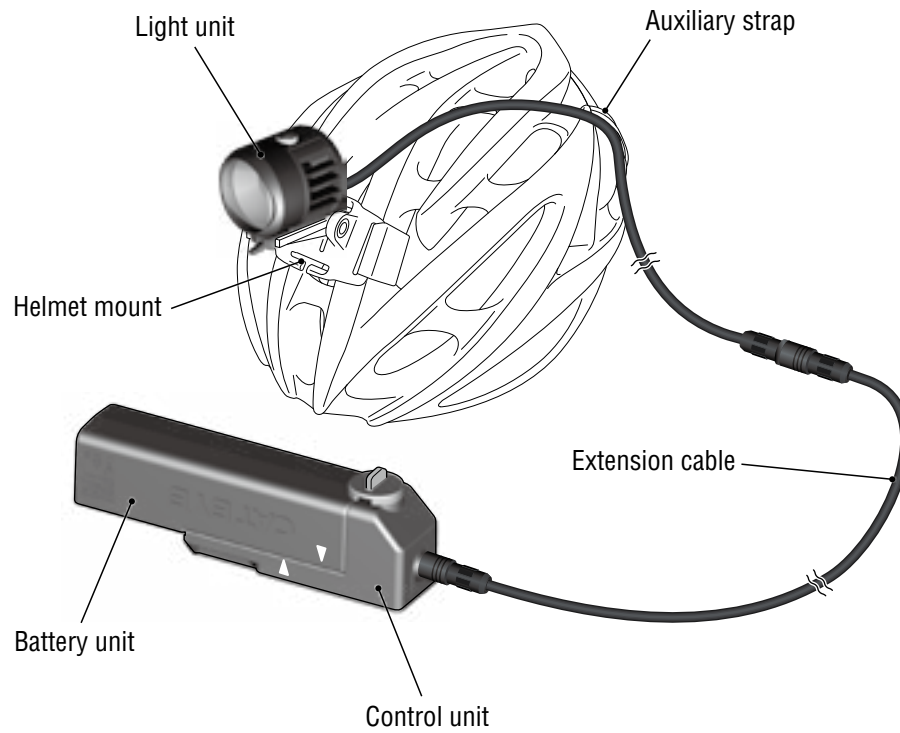

# MOUNTING THE LIGHT UNIT ON A HELMET

(2/3)

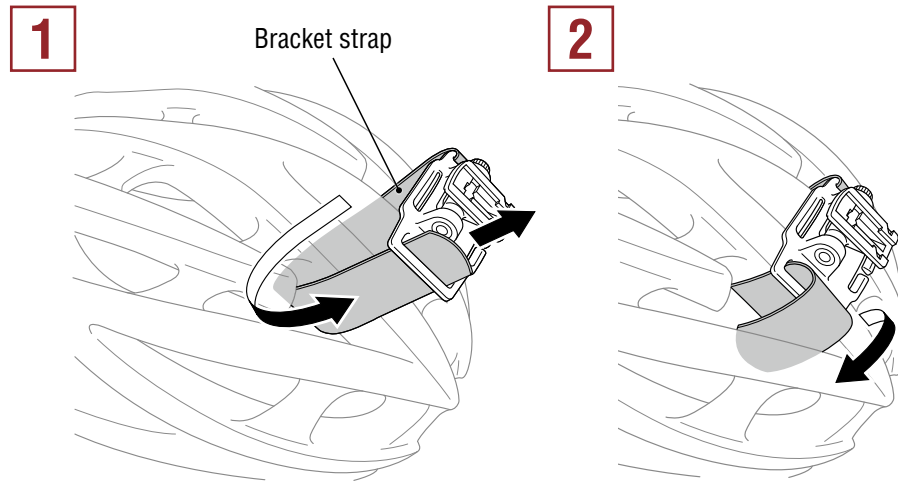

Put the bracket strap through the air vent on the helmet, and secure it firmly.

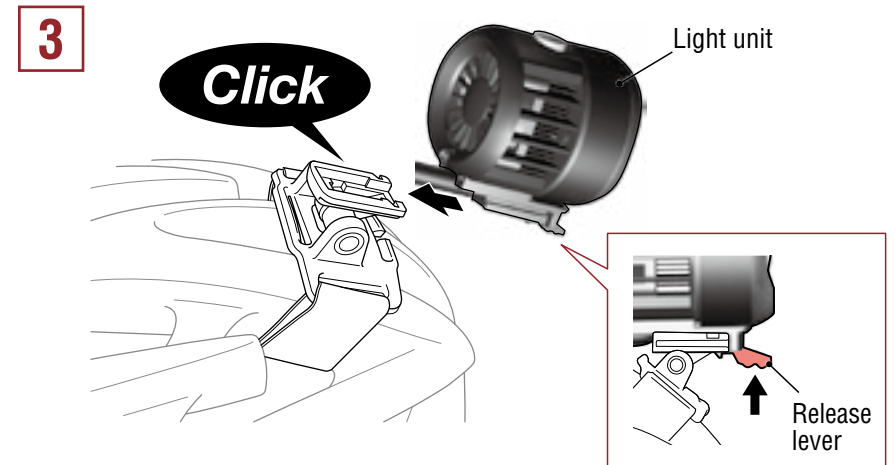

To remove the light unit, pull it forward while pulling up the release lever.

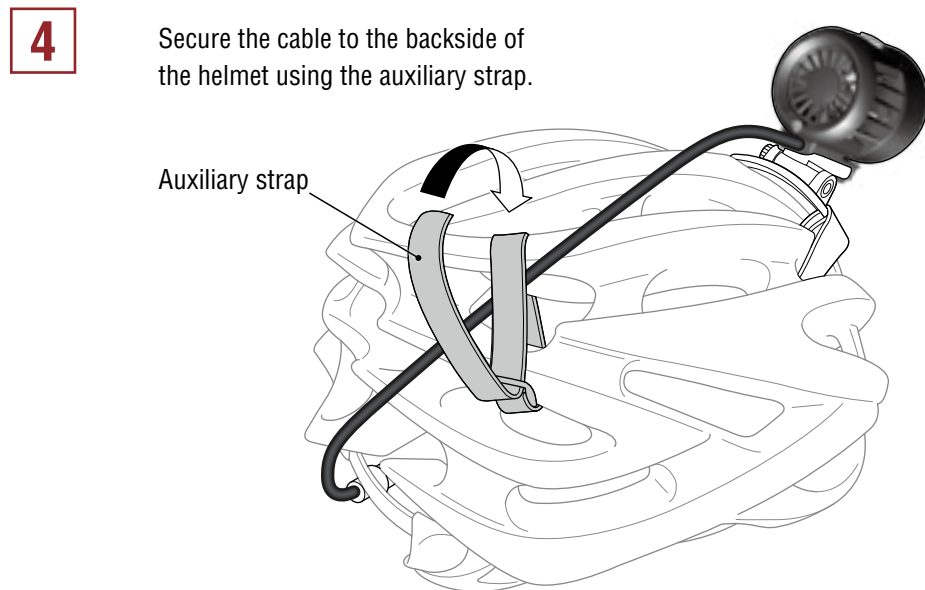

Secure the cable to the backside of the helmet using the auxiliary strap.

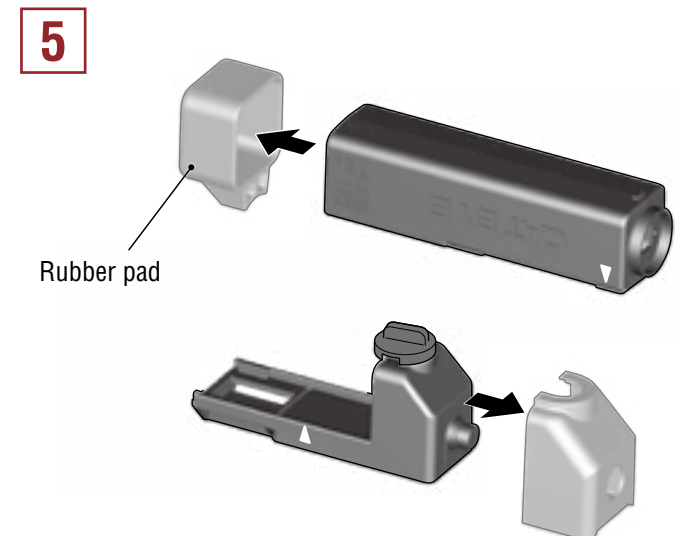

# MOUNTING THE LIGHT UNIT ON A HELMET

(3/3)

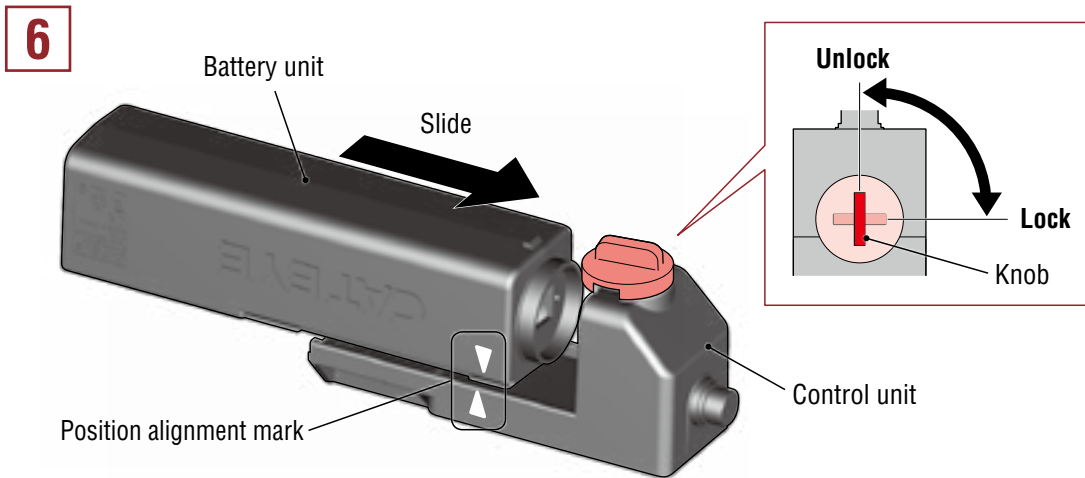

Set the knob of the control unit to the “Unlock” position, align the battery unit with the position alignment mark, and then slide the battery unit into place.

**⚠ CAUTION!** After you connect the battery unit, be sure to set the knob back to the “Lock” position to lock the battery unit in place.

To remove the battery unit, set the knob to the “Unlock” position, and then pull out the battery unit.

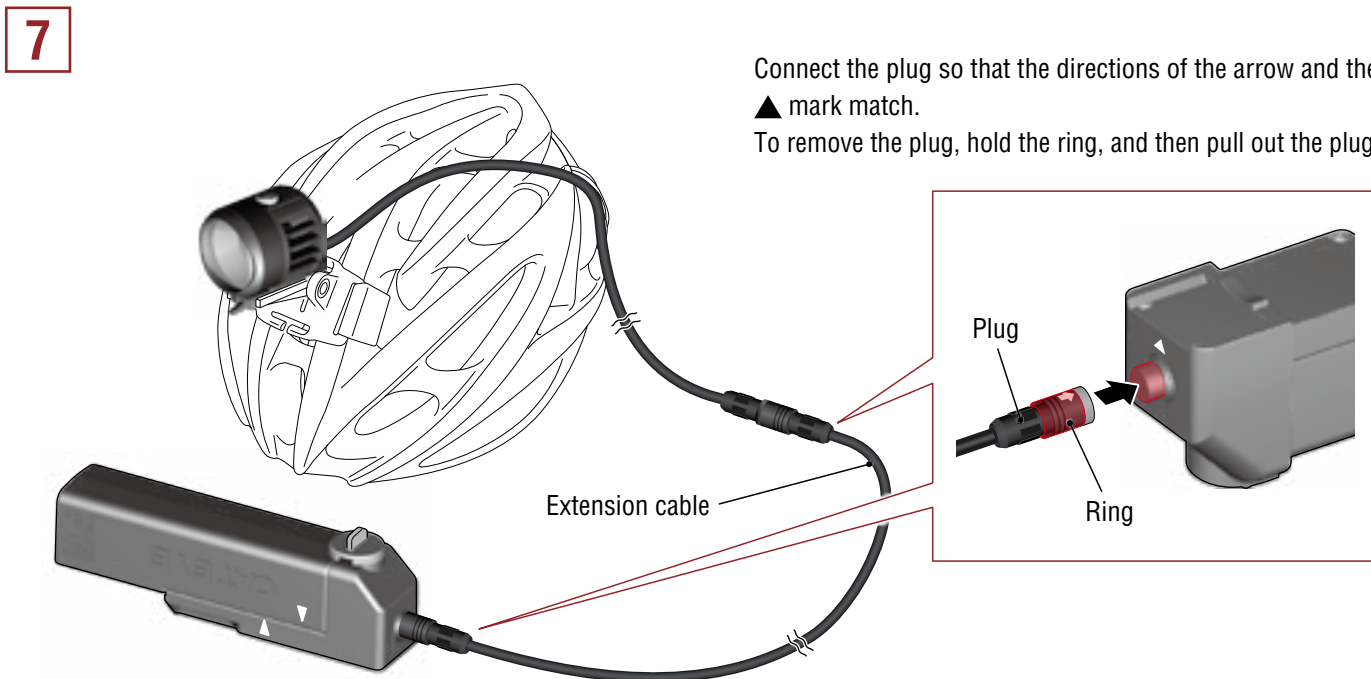

# MOUNTING AND PAIRING THE REMOTE CONTROL SWITCH

## How to mount

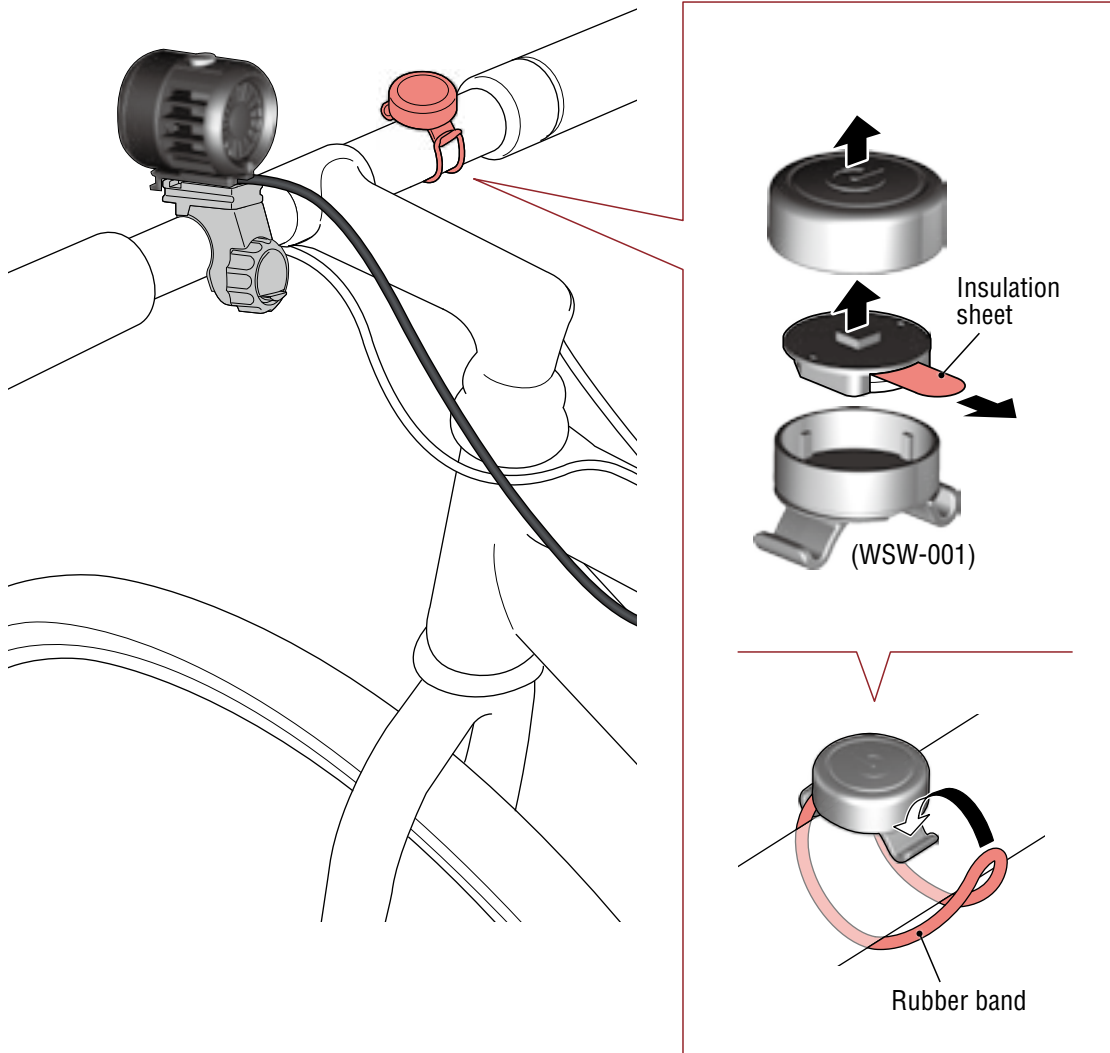

## How to pair

Follow the steps below to pair the remote control switch with a light unit.

\* The included remote control switch has been paired with the light unit at the factory, so pairing is not necessary before use.

**⚠ CAUTION!:**

- Do not look directly at the light when it is on.
- Perform pairing within 1 m from each other.

1. Press and hold the switch on the light unit for 4 seconds. The switch will flash and await a signal (pairing mode) for 5 minutes.

\* Keep pressing the switch even when the light turns on.

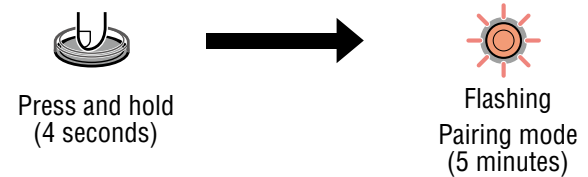

\* To exit the pairing mode, press the switch on the light unit.

2. Pressing the remote control switch while the light unit is in pairing mode will flash the light three times and complete the pairing. Press the remote control switch to check that the light turns on.

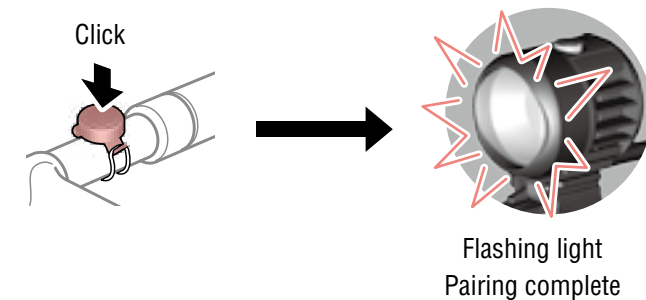

# SWITCH OPERATION

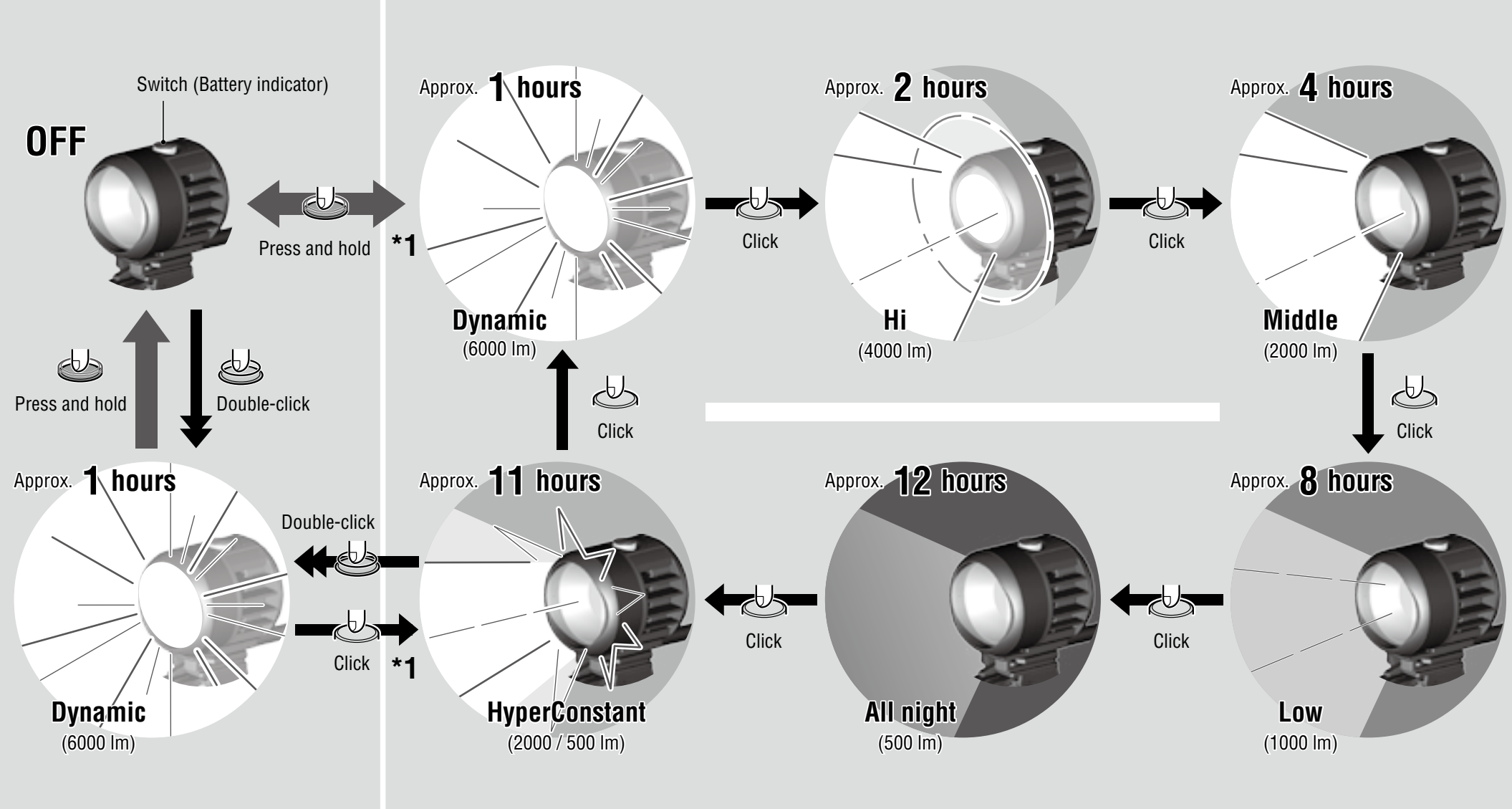

\*1 Mode memory function : The lighting mode will be recorded, and the light will turn on in this mode the next time as well.

\* When the switch lights up, the remaining battery power is 20% or less. Charge the battery as soon as possible.

# PROTECTION FUNCTIONS

## Temperature control

If the temperature of the light unit increases abnormally while the light is on, the protection circuit will activate, and the lighting mode will be decreased by a level. In this situation, if the light unit temperature decreases, the lighting mode will be returned to its previous level.

## Cooling fan stoppage

If, for any reason, the cooling fan stops, the light unit's switch will flash. If you leave the light on in this state and the temperature of the light unit increases, the lighting mode will be decreased by a level. In this situation, the lighting mode will not return to its previous level until you turn the power off.

If the fan stops, follow the procedure in "Removing the protective cover" to remove the protective cover, and then use a gas duster or similar tool to remove the cause of the fan stoppage. Follow the procedure in reverse to attach the protective cover.

## REMOVING THE PROTECTIVE COVER

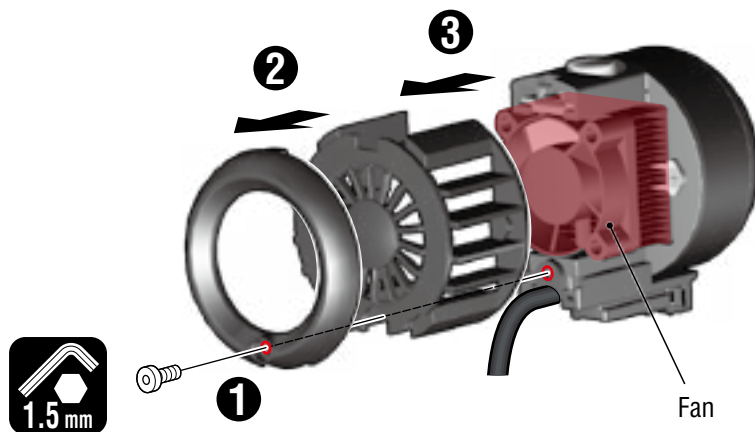

# REPLACING THE REMOTE CONTROL SWITCH BATTERY

After you replace the battery, check that the light turns on when you press the remote control switch near the control unit. If it does not turn on by pressing the paired remote control switch, it may be at the end of battery life. Replace it with a new battery.

**⚠ CAUTION!** Do not look directly at the light when it is on.

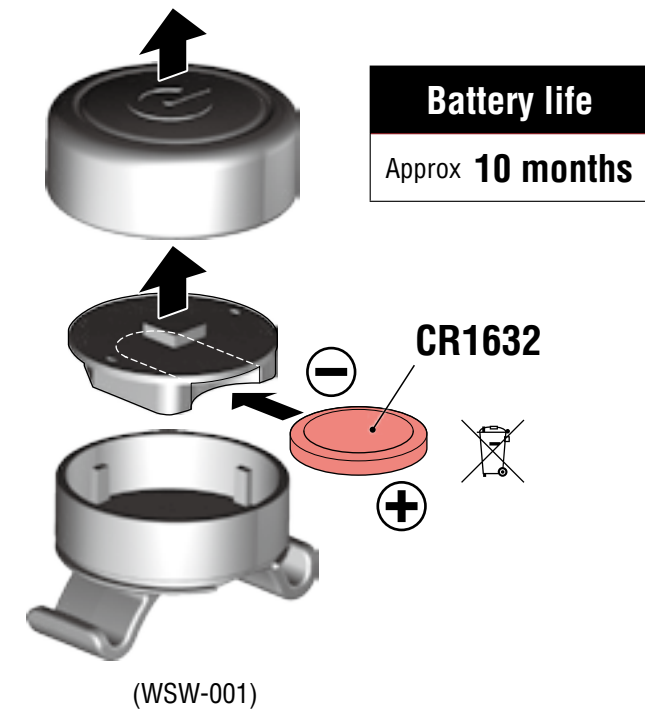



# SPARE/OPTIONAL PARTS



**5343020**

Light unit

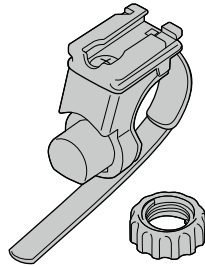

**5338829N**

FlexTight™ bracket  
(H-34N HP)

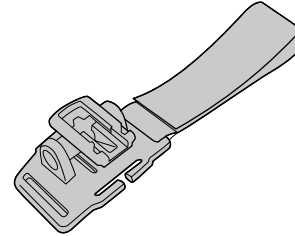

**5341832N**

Helmet mount  
(Helmet mount HP)

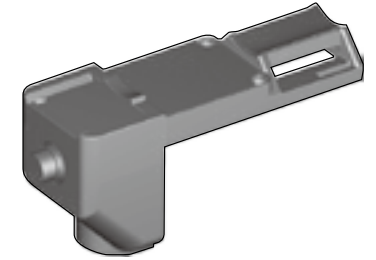

**5343040**

Control unit

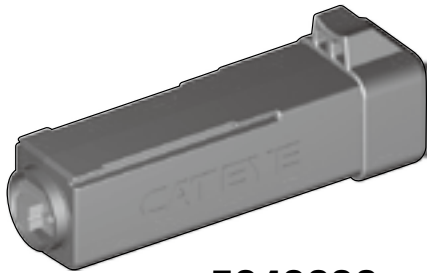

**5343030**

Battery unit  
(BA-608)

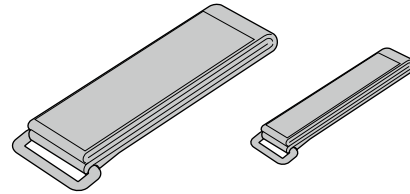

**5343050**

Fixing strap

**5342180**

Auxiliary strap



**5343080**

Extension cable

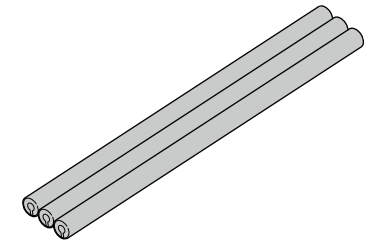

**5342190**

Cable cover



**5343070**

Remote control switch  
(WSW-001)

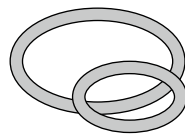

**5447010**

Rubber band



**1603860**

Lithium battery  
(CR1632)

**UK 5343061**

**UL 5343062**

**EC 5343063**

**AS 5343064**

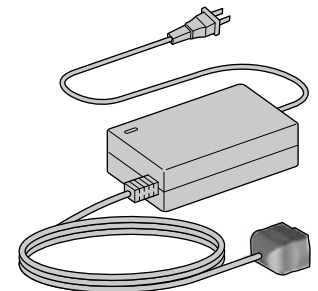

Battery charger

# SPECIFICATIONS

Light source	COB LED
Battery unit	Lithium-ion rechargeable battery BA-608 Li-ion/14.4V 6800mAh
Battery charger	CHR-002 Li-ion (AC100V – 240V 50/60Hz)
Remote control switch	Lithium battery (CR1632) x 1 (Approx 10 months)
Temperature range	Charging : 5°C – 40°C, Operating : -10°C – 40°C
Recharge/discharge number of times	About 300 times (until the rated capacity drops to 60%)
Dimensions/weight	
Light unit	1-27/32" x 2-21/64" x 2-3/64" (47 x 59 x 52 mm) / 4.16 oz (118 g) (Including the bracket and cable)
Control unit/battery unit	7-27/32" x 1-13/16" x 2-43/64" (199 x 46 x 68 mm) / 19.4 oz (550 g)
Remote control switch	1-9/64" x 1-27/64" x 53/64" (29 x 36 x 21 mm) / 0.35 oz (10 g)

\* The specifications and design are subject to change without notice.

# LIMITED WARRANTY

## 2-year Warranty: Light unit / Control unit / Battery unit / Battery charger / Remote control switch (Battery deterioration is not covered)

CatEye products are warranted to be free of defects from materials and workmanship for a period of 2 years from original purchase. If the product fails to work during normal use, CatEye will repair or replace the defect at no charge. Service must be performed by CatEye or an authorized retailer. To return the product, pack it carefully and enclose the warranty certificate (proof of purchase) with instruction for repair. Please write or type your name and address clearly on the warranty certificate. Insurance, handling and transportation charges to CatEye shall be borne by person desiring service.

For UK and REPUBLIC OF IRELAND consumers, please return to the place of purchase. This does not affect your statutory rights.

Please register your CatEye product on the website.  
<http://www.cateye.com/en/support/regist/>

### CATEYE CO., LTD.

2-8-25, Kuwazu, Higashi Sumiyoshi-ku,  
Osaka 546-0041 Japan

Attn: CATEYE Customer Service Section

Phone : (06)6719-6863

Fax : (06)6719-6033

E-mail : support@cateye.co.jp

URL : <http://www.cateye.com>

### [For US Customers]

### CATEYE AMERICA, INC.

2825 Wilderness Place Suite 1200,  
Boulder CO 80301-5494 USA

Phone : 303.443.4595

Toll Free : 800.5.CATEYE

Fax : 303.473.0006

E-mail : service@cateye.com