



CATEYE

VELO WIRELESS

CYCLOCOMPUTER CC-VT200W

Owner's Manual

U.S. Pat. Nos. 5236759/5308419/6957926 Pat./Design Pat. Pending
 Copyright© 2017 CATEYE Co., Ltd.
 CCVT200W-170830 4



INSTALL

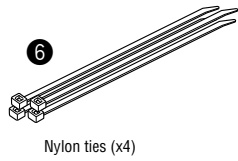
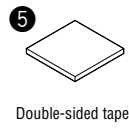
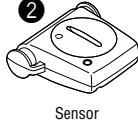
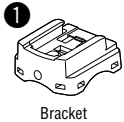

A

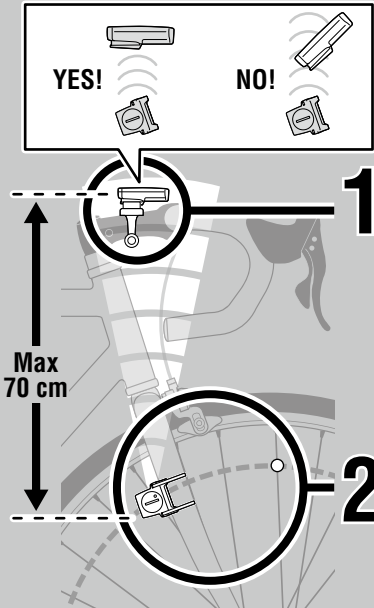

1 Bracket

[Stem]

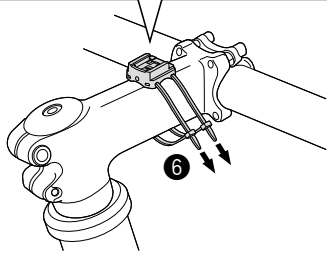
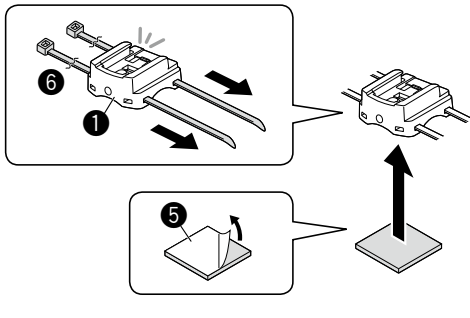

or

[Handlebar]

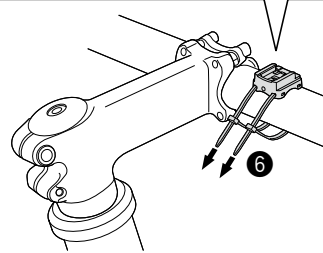
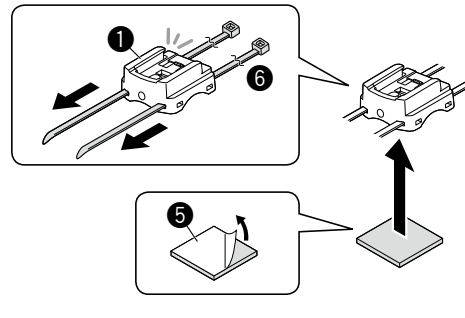

2 Sensor/Magnet

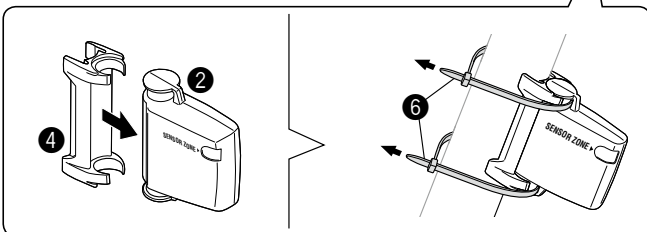
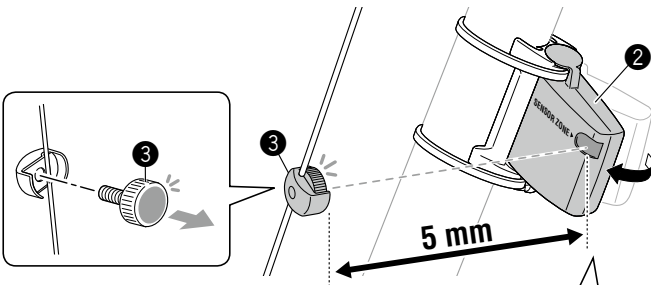

B

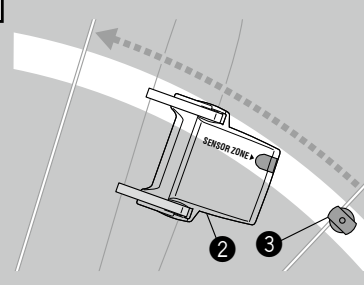

C

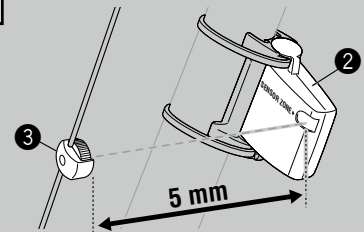

ENG

CC-VT200W VELO WIRELESS

SETTING

1 | All Clear

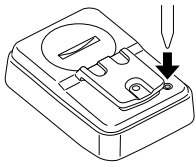

TM = 0
 DST = 0
 AV = 0
 MX = 0
 ODO = 0
 = 0

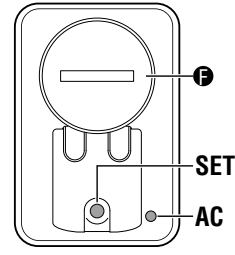
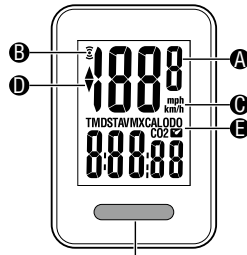

- A Current speed
- B Sensor signal icon
- C Speed unit km/h mph
- D Pace arrow ▲▼

- F Selected mode
 - G Battery case cover
- * Refer to "Element names" for details.

2 | Select km/h or mph

Set: km/h

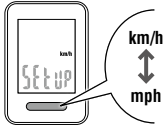

Register the setting

3 | Tire Size

[Quick setting size]



TIRE SIZE
 27 x 1 - 1/4
 Set: 27"

or

[Detailed setting size]



ETRTO	Tire size	L (cm)
28-630	27x1-1/8	216
32-630	27x1-1/4	216
37-630	27x1-3/8	217
18-622	700x18c	207

Set: 216

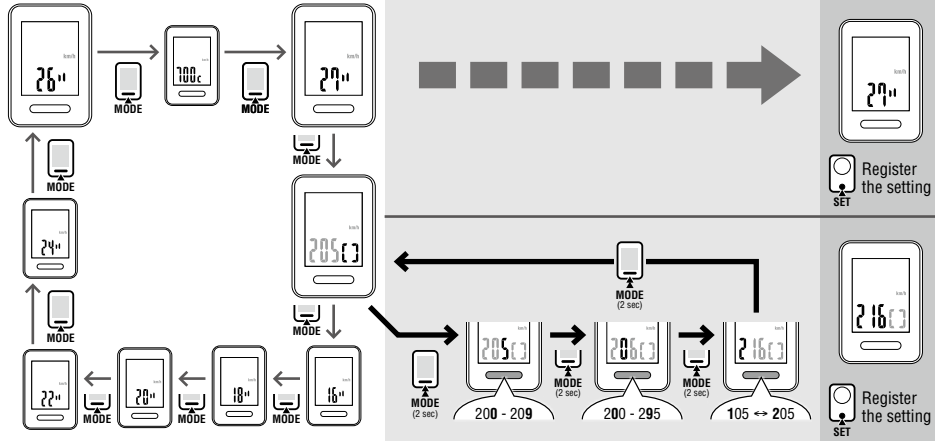

Register the setting

Register the setting

4 | Clock Setting

Set: 12h - 3:10

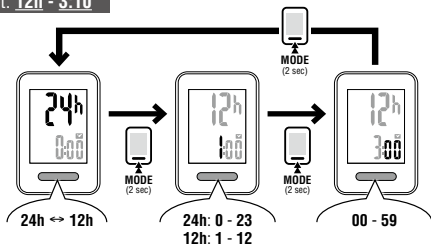

Register the setting (Finish)

OPERATION FLOW

Current Speed
 0.0(4.0) - 105.9 km/h
 [0.0(3.0) - 65.9 mph]

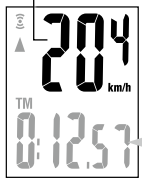

TM 0:12:57
 TM 0:00.00 - 9:59.59

DST 1.23
 DST 0.00 - 999.99 km [mile]

AV 14.6
 AV *1
 0.0 - 105.9 km/h
 [0.0 - 65.9 mph]

MX 30.1
 MX
 0.0(4.0) - 105.9 km/h
 [0.0(3.0) - 65.9 mph]

ODO 12345
 ODO
 0 - 99999 km [mile]

15:38

 0:00 - 23:59
 [1:00 - 12:59]

Data Reset



TM = 0
 DST = 0
 AV = 0
 MX = 0

Battery

Computer

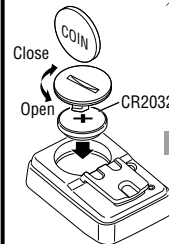

SETTING
 1. All clear

Sensor

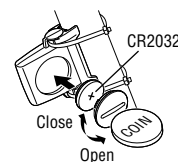

Before using the computer, please thoroughly read this manual and keep it for future reference.

WARNING / CAUTION

- Do not concentrate on the computer while riding. Ride safely!
- Install the magnet, sensor, and bracket securely. Check these periodically.
- If a child swallows a battery, consult a doctor immediately.
- Do not leave the computer in direct sunlight for a long period of time.
- Do not disassemble the computer.
- Do not drop the computer to avoid malfunction or damage.
- When cleaning the computer, bracket and sensor, do not use thinners, benzene, or alcohol.
- Risk of explosion if battery is recharged by an incorrect type. Dispose of used batteries according to local regulations.
- LCD screen may be distorted when viewed through polarized sunglass lenses.

Wireless Sensor

The sensor was designed to receive signals within a maximum range of 70 cm, to reduce chance of interference. When adjusting the wireless sensor, note the following:

- Signals cannot be received if the distance between the sensor and the computer is too large.
- The receiving distance may be shortened due to low temperature and exhausted batteries.
- Signals can be received only when the back of the computer is facing the sensor.
- Interference may occur, resulting in incorrect data, if the computer is:
 - Near a TV, PC, radio, motor, or in a car or train.
 - Close to a railroad crossing, railway tracks, TV stations and/or radar base.
 - Using with other wireless devices in close proximity.

Install the sensor and magnet

- A** The distance between the computer and the sensor must not exceed the transmission range of 70 cm. The back of the computer must face the sensor.
 - B** The magnet passes through the sensor zone.
 - C** The clearance between the sensor and magnet is 5 mm or less.
- * The magnet may be installed anywhere on the spoke if the above installation conditions are satisfied.

Element names

- Current speed**
- Sensor signal icon**
Flashes in synch with a sensor signal.
- Speed unit km/h mph**
- Pace arrow**
Indicates whether the current speed is faster (▲) or slower (▼) than the average speed.
- Selected mode**
Indicates the data currently selected.
 - TM**Elapsed Time **DST**..... Trip Distance
 - AV¹**Average Speed **MX**..... Maximum Speed
 - ODO**.....Total Distance **☑**..... Clock

*1 When **TM** exceeds about 27 hours, or **DST** exceeds 999.99 km, **E** will appear. Reset the data.
- Battery case cover**

Starting/Stopping measurement

Measurements start automatically when the bicycle is in motion. During measurement, **km/h** or **mph** flashes.

Switching computer function

Pressing **MODE** switches the measurement data at the bottom in the order of **OPERATION FLOW**.

Resetting data

Pressing and holding **MODE** on the measuring screen returns the measurement data to 0. The odometer is not reset.

Power-saving mode

If the computer has not received a signal for 10 minutes, power-saving mode will activate and only the clock will be displayed. When the computer receives a sensor signal, the measuring screen reappears. If another 2 weeks' inactivity elapsed, **SLEEP** will be displayed on the screen. Pressing the **MODE** in **SLEEP** mode brings up the measuring screen.

Maintenance

To clean the computer or accessories, use diluted neutral detergent on a soft cloth, and wipe it off with a dry cloth.

Replacing the battery

- Computer**
When the display appears dim, or the computer hardly receives a sensor signal, replace the battery. Install a new lithium battery (CR2032) with the (+) side facing upward.
* After replacing the computer battery, follow the procedure described in **SETTING**.
- Sensor**
When the speed is not displayed even after adjusting correctly, replace the battery. After replacement, check the positions of the sensor and magnet.

Troubleshooting

The sensor signal icon does not flash (the speed is not displayed). (Move the computer near the sensor, and turn the front wheel. If the sensor signal icon flashes, this trouble may be a matter of transmission distance due to battery drain, but not any malfunction.)
 Check that the clearance between the sensor and magnet is not too large. (Clearance: within 5 mm)
 Check that the magnet passes through the sensor zone correctly. Adjust the positions of the magnet and sensor.
 Is the computer installed at the correct angle?
 Back of computer must face toward the sensor.
 Check that the distance between the computer and sensor is correct. (Distance: within 20 to 70 cm)
 Install the sensor within the specified range.
 Is the computer or sensor battery weak?
 In winter, battery performance diminishes.
 Replace with new batteries. After replacement, follow the procedure "Replacing the battery".
 No display.
 Is battery in the computer run down?
 Replace it with a new battery. After replacement, follow the procedure described in **SETTING**.
 Incorrect data appear.
 Follow the procedure described in **SETTING**.

Specification

Battery
 Computer : Lithium battery (CR2032) x 1
 Sensor : Lithium battery (CR2032) x 1
Battery life
 Computer : Approx. 1 year (If the computer is used for 1 hour/day; the battery life will vary depending on the conditions of use.)
 Sensor : Unit Total Distance reaches about 10000 km (6250 mile)

* This is the average figure of being used under 20 °C temperature and the distance between the computer and the sensor is 65 cm.

Controller... 4 bit, 1-chip microcomputer (Crystal controlled oscillator)

Display Liquid crystal display
Sensor No contact magnetic sensor

Transmission distance
 Between 20 and 70 cm

Tire size to be selected
 26", 700c, 27", 16", 18", 20", 22" and 24", or tire circumference of 100 cm - 299 cm (initial value: 26 inch)

Working temperature
 32 °F - 104 °F (0 °C - 40 °C) (This product will not display appropriately when exceeding the Working Temperature range. Slow response or black LCD at lower or higher temperature may happen respectively.)

Dimensions/weight
 Computer: 2-3/16" x 1-15/32" x 5/32" (55.5 x 37.5 x 18.5 mm) / 0.99 oz (28 g)
 Sensor : 1-41/64" x 1-3/8" x 1/932" (41.5 x 35 x 15 mm) / 0.53 oz (15 g)

* The factory-loaded battery life might be shorter than the above-mentioned specification.
 * The specifications and design are subject to change without notice.

LIMITED WARRANTY

2-Year Computer/Sensor only (Accessories/Bracket sensor and Battery Consumption excluded)

CatEye cycle computers are warranted to be free of defects from materials and workmanship for a period of two years from original purchase. If the product fails to work due to normal use, CatEye will repair or replace the defect at no charge. Service must be performed by CatEye or an authorized retailer. To return the product, pack it carefully and enclose the warranty certificate (proof of purchase) with instruction for repair. Please write or type your name and address clearly on the warranty certificate. Insurance, handling and transportation charges to CatEye shall be borne by person desiring service.
 For UK and REPUBLIC OF IRELAND consumers, please return to the place of purchase. This does not affect your statutory rights.

CATEYE CO., LTD.

2-8-25, Kuwazu, Higashi Sumiyoshi-ku, Osaka 546-0041 Japan
 Attn: CATEYE Customer Service Section
(For US Customers)
CATEYE AMERICA, INC.
 2825 Wilderness Place Suite 1200, Boulder CO80301-5494 USA
 Phone : 303.443.4595
 Toll Free : 800.5CATEYE
 Fax : 303.473.0006
 E-mail : service@cateye.com
 URL : http://www.cateye.com

Frequency Band : 19 kHz
 Radiated Power : -3.8 dBm (at 10 m)
 Hereby, CATEYE Co., Ltd. declares that the radio equipment type CC-VT200W is in compliance with Directive 2014/53/EU.

The full text of the EU declaration of conformity is available at the following internet address :
 cateye.com/doc

This device complies with Part 15 of the FCC Rules. Operation is subject to the following two conditions:
 (1) This device may not cause harmful interference, and
 (2) This device must accept any interference received, including interference that may cause undesired operation.
Modifications The FCC requires the user to be notified that any changes or modifications made to this device that are not expressly approved by CatEye Co., Ltd. May void the user's authority to operate the equipment.

ETRT0	Tire size	L (cm)
40-254	14x1.50	102
47-254	14x1.75	110
40-305	16x1.50	119
47-305	16x1.75	120
54-305	16x2.00	125
28-349	16x1-1/8	129
37-349	16x1-3/8	130
32-369	17x1-1/4 (369)	134
40-355	18x1.50	134
47-355	18x1.75	135
32-406	20x1.25	145
35-406	20x1.35	146
40-406	20x1.50	149
47-406	20x1.75	152
50-406	20x1.95	157
28-451	20x1-1/8	155
37-451	20x1-3/8	162
37-501	22x1-3/8	177
40-501	22x1-1/2	179
47-507	24x1.75	189
50-507	24x2.00	193
54-507	24x2.125	197
25-520	24x1(520)	175
	24x3/4 Tubuler	179
28-540	24x1-1/8	180
32-540	24x1-1/4	191
25-559	26x1(559)	191
32-559	26x1.25	195
37-559	26x1.40	201
40-559	26x1.50	201
47-559	26x1.75	202
50-559	26x1.95	205
54-559	26x2.10	207
57-559	26x2.125	207
58-559	26x2.35	208
75-559	26x3.00	217
28-590	26x1-1/8	197
37-590	26x1-3/8	207
37-584	26x1-1/2	210
	650C Tubuler 26x7/8	192
20-571	650x20C	194
23-571	650x23C	194
25-571	650x25C 26x1(571)	195
40-590	650x38A	213
40-584	650x38B	211
25-630	27x1(630)	215
28-630	27x1-1/8	216
32-630	27x1-1/4	216
37-630	27x1-3/8	217
18-622	700x18C	207
19-622	700x19C	208
20-622	700x20C	209
23-622	700x23C	210
25-622	700x25C	211
28-622	700x28C	214
30-622	700x30C	215
32-622	700x32C	216
	700C Tubuler	213
35-622	700x35C	217
38-622	700x38C	218
40-622	700x40C	220
42-622	700x42C	222
44-622	700x44C	224
45-622	700x45C	224
47-622	700x47C	227
54-622	29x2.1	229
60-622	29x2.3	233

STANDARD PARTS

#160-2990 : Parts kit

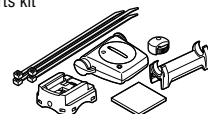

#160-2196 : Speed sensor

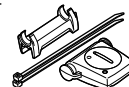

#160-2980 : Bracket

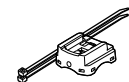

#166-5150 : Lithium battery (CR2032)



#169-9691 : Wheel magnet



CC-VT200W VELO WIRELESS