



# CATEYE CORDLESS

**CYCLOCOMPUTER**

**MODEL CC-CL100**



INSTRUCTION MANUAL

*MODE D'EMPLO*

BETRIEBSANLEITUNG

*BEDIENINGSHANDLEIDING*

MANUAL DE INSTRUCCIONES

ISTRUZIONI PER L'USO

# OPERATING INSTRUCTIONS

## CAT EYE CORDLESS CYCLOCOMPUTER Model CC-CL 100

### INDEX

1. Main Unit .....	3
2. Accessories .....	4
3. Main Unit Preparation .....	5
4. Magnet/ Sensor Mounting .....	8
5. Bracket/ Main Unit Mounting .....	9
6. Test .....	9
7. Cordless system .....	10
8. Measuring and Display Functions .....	11
9. Button Functions .....	14
10. Trouble Shooting .....	15
11. Maintenance/ Precautions .....	16
• Specifications .....	17
• Limited Warranty .....	112

## **Introduction**

Thank you very much for your purchasing a CATEYE CORDLESS CYCLOCOMPUTER Model CC-CL100. This is an entire new typed Cordless cyclocomputer, which transmits and receives the signal of wheel rotation by electromagnetic wave. This cyclocomputer not only can display speed but also measures, stores and displays total distance, trip distance, elapsed time, average speed, maximum speed and clock time. Set the speed scale (mile/h or km/h) and wheel circumference for your bike. Before operating, thoroughly familiarize yourself with this manual so you completely understand the functions of this cyclocomputer, and enjoy computerized cycling. Store this manual in a safe place for your future reference.

# 1 Main Unit

Front View of Main Unit

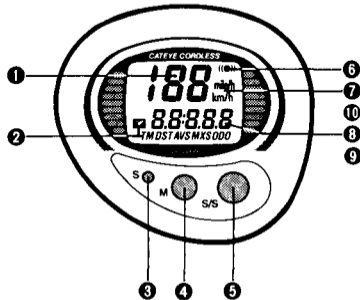

Back View of Main Unit

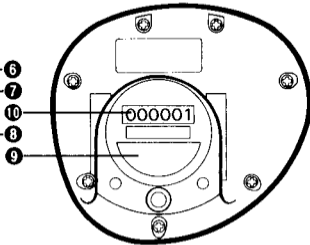

- ① Speed Display
- ② Mode Symbol
- ③ Set Button
- ④ Mode Button
- ⑤ Start/Stop Button
- ⑥ Wheel Sensor Pulse Symbol
- ⑦ Speed Scale Symbol
- ⑧ Selected Function Display
- ⑨ Battery Case Cover
- ⑩ Serial Number

## 2 Accessories

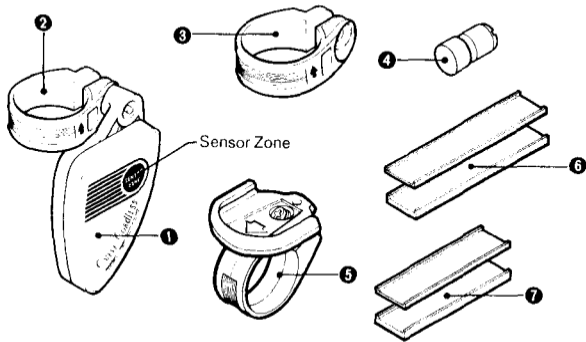

- ① Sensor (Transmitter)
- ② Sensor Band (Small)
- ③ Sensor Band (Large)
- ④ Magnet
- ⑤ Bracket
- ⑥ Sensor Band Rubber Pad  
(1 mm) (2 mm)
- ⑦ Bracket Rubber Pad  
(1 mm) (2 mm)

### 3 Main Unit Preparation



(Fig. 1)

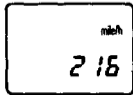

(Fig. 2)



(Fig. 3)

The following must be completed before operating.  
(A battery is already loaded when purchased.)

#### ● Setting Speed Scale

Press all three buttons simultaneously (mode button, start/stop button, set button) to clear all data. All displays will illuminate for 2 seconds. Then mile/h alone will be displayed as illustrated in Fig. 1. Km/h and mile/h are alternately displayed each time when the start/stop button is pressed. Select either as desired. Next, press the mode button, and the speed scale will be set and displayed as shown in Fig. 2.

#### ● Setting the wheel circumference

##### (1) How to measure wheel circumference

Refer to Table 1 in page 7, get the wheel circumference (L) from the tire size of your bike. To get more accurate values, measure the radius R (cm) with the rider on the bicycle as shown in Fig. 3 and calculate the wheel circumference L (cm) using the following formula;  $L = 2 \pi R = 6.283R$  (cm)

##### (2) Setting the wheel circumference

216 (standard wheel circumference (cm) for 27" wheel) is displayed, as shown in Fig. 2. When using 216 cm without revision, press the mode button, and  will be displayed and 216 cm is set. To revise 216 cm, press the start/stop button when the wheel circumference is initially displayed, and 216 will be changed to a flickering 217. Then, the number will increase by 1 every time the start/stop button is pressed. When the button is held down, it will rapidly increase. Select a number in the range of 100 cm to 259 cm according to your bike. When the desired number appears, press the mode button. When  appears, preparation is completed.

##### (3) Resetting or changing the wheel circumference

Get the stop state in the (ODO) mode, and press the set button. The wheel circumference number stored will flicker on the lower line of the display. Revise the number as required according to the instructions given in (2).

\* The stored wheel circumference number is displayed while the mode and start/stop buttons are simultaneously pressed in the (ODO) mode.



(Fig. 4)

CLOSE

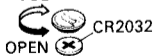

(Fig. 5)

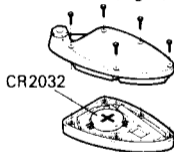

(Fig. 6)

### ●Setting the 24hr clock time

Get the stop state in the (☑) mode, and press the set button. The set time stored appears, and the digits for "minutes" flicker. Press the start/stop button to advance the flickering digits by 1. When the button is held down, it will rapidly increase. Flicker the digits which are ahead of the current time by one or two minutes. Press the mode button. The digits for "hours" flicker. Press the start/stop button to advance the flickering digits. Press the set button to complete the time setting.

\* When the set button is pressed, the time in "seconds" (undisplayed) turns to "0". For accurate 24hr clock setting, use your radio time signal on the hour.

### ●How to replace the battery

\* A batteries is already loaded each in the main unit and in the sensor with transmitter. Replace both batteries periodically following the instruction as below. (See page 10 for the battery life.)

#### ● How to replace the battery in the main unit.

Turn the main unit over, remove the battery case cover using coin or similar opener as illustrated in Fig. 5, and insert a new lithium battery (CR 2032). Positioning the (+) pole upward as illustrated, place the battery properly into the case and close the cover securely.

#### ● How to replace the battery in the sensor.

Replace the battery at about every 10,000 miles (16,000 km).

1. Take off the sensor unit from bicycle.
2. Open the sensor case by removing five (5) set screws, and replace the battery with new Lithium battery (CR 2032). Positioning the (+) pole upward as illustrated in Fig. 6, place the battery properly.
3. Check if the O ring is set properly, and assemble the case by tightening five (5) set screws.
4. Mount the sensor unit to your bike, and adjust its relative position and clearance.

**Table 1. Setting Values Cross Reference Table**

D (inch)                      L (cm)  
Tire diameter              Circumference

D (inch)	L (cm)	D (inch)	L (cm)	D (inch)	L (cm)	D (inch)	L (cm)	D (inch)	L (cm)	D (inch)	L (cm)
14 1/2	116	7/8	135	1/4	154	5/8	173	24.0	192	3/8	211
5/8	117	17.0	136	3/8	155	3/4	174	1/8	193	1 1/2" * Tubular	212
3/4	118	1/8	137	1/2	156	7/8	175	1/4	194	5/8	213
7/8	119	1/4	138	5/8	157	22.0	176	3/8	195	3/4 700x28C	214
15.0	120	3/8	139	3/4	158	1/8	177	1/2	196	7/8	215
1/8	121	1/2	140	7/8	159	1/4	178	5/8	197	27.0 700x32C	216
1/4	122	5/8	141	20.0	160	3/8	179	3/4	198	1/8	217
3/8	123	3/4	142	1/8	161	1/2	180	7/8	199	1/4	218
1/2	124	7/8	143	1/4	162	5/8	181	25.0	200	3/8	219
5/8	125	18.0	144	3/8	163	3/4	182	1/8	201	1/2	220
1/4	126	1/8	145	1/2	164	7/8	183	1/4	202	5/8	221
7/8	127	1/4	146	5/8	165	23.0	184	3/8	203	1/4	222
16.0	128	3/8	147	3/4	166	1/8	185	1/2	204	7/8	223
1/8	129	1/2	148	7/8	167	1/4	186	5/8	205	28.0 700B	224
1/4	130	5/8	149	21.0	168	3/8	187	1/4	206	1/8	225
3/8	131	3/4	150	1/8	169	1/2	188	7/8	207	1/4	226
1/2	132	7/8	151	1/4	170	5/8	189	26.0 650A	208	3/8	227
5/8	133	19.0	152	3/8	171	1/4	190	1/8 650B	209	1/2	228
3/4	134	1/8	153	1/2	172	7/8	191	1/4 700x25C	210	5/8	229



## 4 Magnet/Sensor Mounting

### Installation view of Sensor/Magnet Mounting

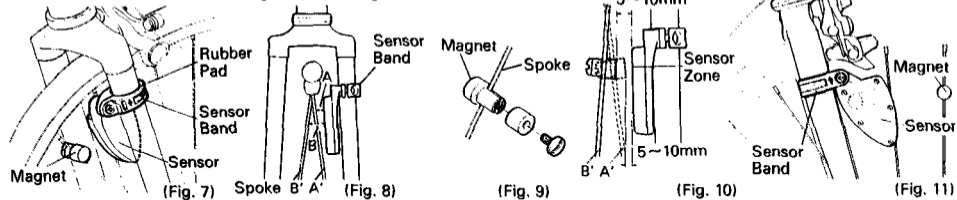

- (1) Mount sensor onto upper inside of right front fork facing the wheel as shown in Fig. 7. Use either the large or small sensor band and either the 1 mm- or 2 mm-thick rubber pad, whichever matches the tube diameter of your bike. Temporarily affix the sensor maintaining clearance (A or B) of 11 - 16 mm from the spoke (A' or B') as shown in Fig. 8. Confirm the arrow mark on the sensor band shows upward.
- (2) Mount the magnet on the spoke (A' or B') whichever maintains clearance. Align the magnet with the sensor zone of the sensor (See Fig. 9).
- (3) Turning the sensor together with the sensor band, adjust clearance between the sensor and the magnet to 5 - 10 mm and tighten the clamping screw securely. (See Fig. 10).

Note: If the distance between the two fork blades is very narrow and the magnet and the sensor hit each other, take off the sensor from the sensor band, turn the sensor band and mount the sensor again as shown in Fig. 11. Confirm the arrow mark on the sensor band shows upward.

## 5 Bracket/Main unit Mounting

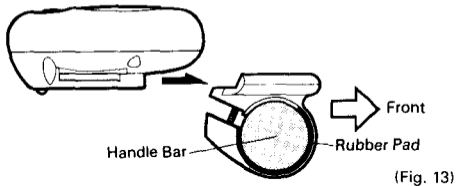
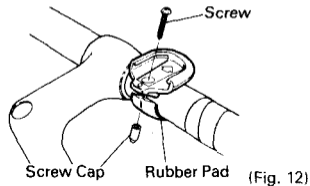

Use either the 1 mm- or the 2 mm-thick rubber pad if necessary, according to the handlebar diameter. Attach the bracket close to the handlebar stem as shown in Fig. 12 and tighten the screw so that the bracket cannot turn. Mount the main unit onto the bracket by sliding it from rear to the front until it clicks into position. When removing the computer, pull it off rearwardly. (See Fig. 13.)

## 6 Test

Mount the main unit on the bracket. If upper line of display does not show any figures, press either Mode button or Start/Stop button to release from power saving function and display the figures. Clear the front wheel off the ground and spin the wheel to check if the wheel sensor pulse symbol will be on and off on the display. If not, adjust relative positions of magnet and sensor following the instructions on Page 8.

## 7 Cordless system

This cyclocomputer pick up the signal of wheel rotation by a sensor and the sensor transmits the signal by electromagnetic wave to the main unit. The main unit receives the signal and calculate and display the data. A lithium battery (CR 2032) is loaded each in the main unit and in the sensor. Approximate battery life will be:

- The main unit (Receiver) ---- About two years (if you used 1hr each day).  
When the display faded, replace the battery to new one.
- The sensor (Transmitter) ---- About 10,000 miles (16,000 km)

Note: Bettery life is based on the following conditions:

The distance between the upper part of the sensor and bottom part of the main unit is 45 cm at normal temperatures.

Always keep the distance between the upper part of the sensor and the bottom part of the main unit within 50 cm. When the battery is getting weak or the temperature falls, the computer will not receive data consistently. In such a case, replace the batteries.

Note: The cordless system may be interfered in the following cases and the main unit may display incorrect figures.

1. Nearby railroad crossing, or in the train.
2. Where intense electromagnetic wave or field exist, i. e. Radio or TV transmission station, or Radar base.
3. When two bicycles carrying similar computers are running side by side within the foul clearance.

### ● Power saving function

When the main unit is left without receiving any input for 30 - 35 minutes continuously, the power will be automatically saved and the main unit will display the clock time (  ) only as shown in Fig. 14. Under this power saving mode, the main unit will not display any speed data even you start cycling. Press either Mode button or Start/Stop button to release power saving mode and display the speed data.

- \* Before you start cycling, always make sure that the speed data appear on the display.  
(If you press the Mode button and Set button simultaneously, the display will turn to the power saving mode.)

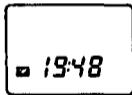

(Fig. 14)

## 8 Measuring and Display Functions

**SPD**

**Current Speed**

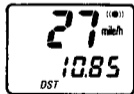

The current speed is displayed on the upper line of the display and updated once a second over a range of 0(3) to 65 miles/h (0(4) to 105 km/h). The upper limit of measurable speed depends on the wheel size as shown in the table.

1	Wheel size	Inch	20	22	24	26	27	28
2	Speed limit	(mile/h)	48	53	58	63	65	68
		(km/h)	78	86	93	101	105	109

**TM**

**Elapsed Time**

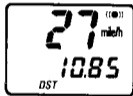

The elapsed time is measured from the starting point to the current point, and displayed on the lower line of the display in units of hours, minutes and seconds. The range is 0:00:00 to 9:59:59 in second increments. When 10 hours have elapsed, the counter returns to zero and time calculation is restarted.

**DST****Trip Distance**

The trip distance from the starting point to the current point is calculated and displayed on the lower line of the display. The range is 0.00 to 999.99 miles (km) in 0.01 mile (km) increments. When 1,000 miles (km) are reached, the trip distance returns to zero and counting begins anew.

**AVS****Average Speed**

The average speed is calculated on the basis of the elapsed time and the trip distance from the starting point to the current point, and displayed on the lower line of the display. Measurable up to 27 hours 46 minutes 39 seconds (99,999 seconds) for the elapsed time or 999.99 miles (km) for the trip distance. If either is exceeded, "E" is displayed and calculation ceases.

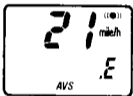

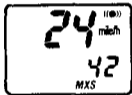
**MXS****Maximum Speed**

The maximum speed is stored in memory and displayed on the lower line of the display. Measurable in the range of 0(3) to 65 miles/h. (0(4) to 105 km). The upper limit is the same as the current speed.

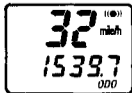
**ODO****Total Distance (Odometer)**

The total distance is continuously measured, accumulated and displayed on the lower line of the display until the battery wears down or all clear operation is done. The range is 0.0 to 9999.9 miles (km) in 0.1 mile (km) increments. When 10,000 miles (km) are reached, the odometer returns to zero and counting begins anew.

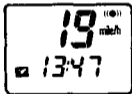
**24hr clock time**

The current time is displayed by a 24 hr clock.

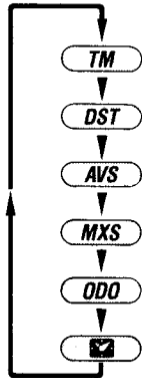

● **Mode Button (M)**

The display mode mark shifts in the illustrated sequence each since the button is pressed, and the corresponding data is simultaneously displayed on the lower line of the display.

● **Start/Stop Button (S/S)**

Measurement of the trip distance and elapsed time is simultaneously started or stopped when the start/stop button is pressed. During operation the speed scale symbol flashes.

● **Set Button (S)**

This button is used for setting the wheel circumference and clock time, and to clear all preset data and any irregularity.

- To set the wheel circumference: Get the stop state in the ODO mode, and press the set button.
- To set the clock time: Get the stop state in the  mode, and press the set button.

○ **RESET:**

Select any mode except total distance (ODO), and press the mode button and start/stop button simultaneously. (Maximus speed (MXS), trip distance (DST), average speed (AVS) and elapsed time (TM) should be zero.)

○ **ALL CLEAR:**

When the mode button, start/stop button and set button are pressed simultaneously, all data stored in memory (including ODO, speed scale, wheel circumference and clock time) are cleared, all displays illuminate for 2 seconds, then the mile/h symbol illuminates. This operation should only be executed after replacing the battery or when irregular display of information occurs due to static electricity etc. Since all the memories are erased, set the necessary data again according to "Main Unit Preparation" (Page 5, 6).

## 10 Trouble Shooting

The following situations do not indicate malfunction of the Cyclocomputer.  
Check the following before taking it for repairs.

Trouble	Check Items	Remedy
The entire liquid crystal screen is dark and unusual display is seen where it should not be.	Wasn't it left for a long time under direct sun?	It returns to normal state if left in the shade. No adverse effect on data.
Display response is slow.	Isn't it at a low temperature under 32°F (0°C)?	It returns to normal state when temperature rises.
No display.	Hasn't the Lithium Battery in the main unit worn out?	Replace the Lithium Battery with a new one.
Incorrect data appears.		Execute "All Clear" operation (Page 14).
Current speed does not appear.	Isn't the distance between sensor and magnet too far?	Refer to "Magnet/Sensor Mounting" (Page 8) and re-adjust correctly.
	Are the sensor zone and the magnet matched each other?	
	Isn't it in the power saving mode (☑ display only and no figures on the upper line)?	Press Mode or Start/Stop button to release power saving mode and display the figures on the upper line.



Trouble	Check Items	Remedy
Current speed does not appear.	Hasn't the Lithium Battery in the sensor worn out?	Replace the Lithium Battery with a new one.
Maximum Speed is abnormally high.	Interference by environmental electromagnetic wave or field?	Reset the main unit.

## 11 Maintenance/Precautions

- Do not leave the main unit exposed to direct sunlight when the unit is not in use.
- Do not disassemble the main unit, sensor and magnet.
- Don't pay too much attention to your computer's functions while riding! Keep your eyes on the road and give due consideration to traffic safety.
- Check relative position of sensor and magnet periodically.
- For cleaning, use neutral detergent on soft cloth, and wipe off later with dry cloth. Do not apply paint thinner, benzine, or alcohol, to avoid damages on the surface.

Specifications			
Functions	Current Speed	<b>SPD</b>	0 (3) ~ 65 miles/h (27 inches) 0 (4) ~ 105 km/h
	Elapsed Time	<b>TM</b>	0:00'00" ~ 9:59'59"
	Trip Distance	<b>DST</b>	0.00 ~ 999.99 miles or km
	Average Speed	<b>AVS</b>	0.0 ~ 65.0 miles/h · 105.0 km/h
	Maximum Speed	<b>MXS</b>	0 (3) ~ 65 miles/h (27 inches) 0 (4) ~ 105 km/h
	Total Distance	<b>ODO</b>	0.0 ~ 9999.9 miles or km
	24 hr clock time	<input checked="" type="checkbox"/>	0:00' ~ 23:59'
Controller	4 - bit 1 - chip Microcomputer (Crystal Controlled Oscillator)		
Display	Liquid Crystal		
Sensor	No Contact Magnetic Sensor		
Cordless system	Directional Electromagnetic Induction		
Power Supply	Main unit	Lithium Battery (CR 2032) × 1	
	Sensor with transmitter	Lithium Battery (CR 2032) × 1	

Specifications		
Operating Temperature Range		0°C ~ 40°C (32°F ~ 104°F)
Storage Temperature Range		-20°C ~ 50°C (-4°F ~ 122°F)
Applicable Cycle Sizes		100 cm ~ 259 cm
Standard Accuracy	Current Speed	± 1 mile/h or km/h under 31 miles/h (50 km/h)
	Elapsed Time	± 0.003 %
	Trip Distance	± 0.01 mile or km
	Average Speed	± 0.2 mile/h or km/h
	Maximum Speed	± 1 mile/h or km/h
	Total Distance	± 0.1 mile or km
	24hr clock	± 0.003 %
Battery Life	Main Unit	About 2 years (1 hour/day)
	Sensor with transmitter	About 10,000 miles (16,000 km)
Dimension/Weight		2-9/32" × 2-1/2" × 15/16" (58 × 63 × 24 mm) / 1.8oz (50g)

The specifications and design are subject to change without notice.  
 This computer converts 1 mile as 1/0.62 km.