

CATEYE MICRO Wireless

CYCLOCOMPUTER

CC - MC100W

Owner's Manual



U.S. Pat. Nos. 4633216/4636769/4642606/5236759 and Design Pat. Pending
Copyright© 2011 CATEYE Co., Ltd.
CCMC1W-110930 066600370 4



Max.
Distance
70 cm

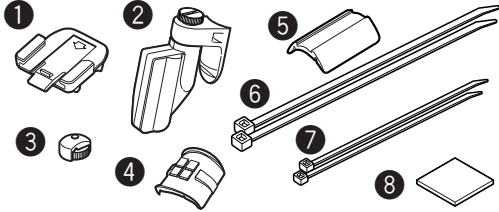
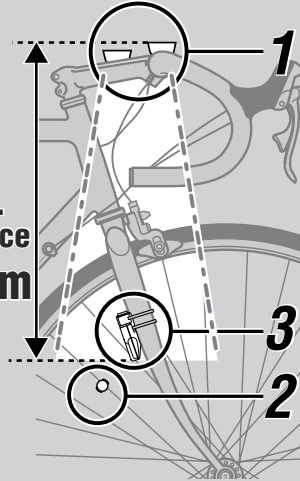

Název součástí

- ① Držák
- ② Bezdrátový snímač (vysílač) A
- ③ Magnet
- ④ Gumová podložka pod držák
- ⑤ Gumová podložka pod snímač
- ⑥ Upevňovací pásky (L x2)
- ⑦ Upevňovací pásky (S x2)
- ⑧ Oboustrannná lepicí páska

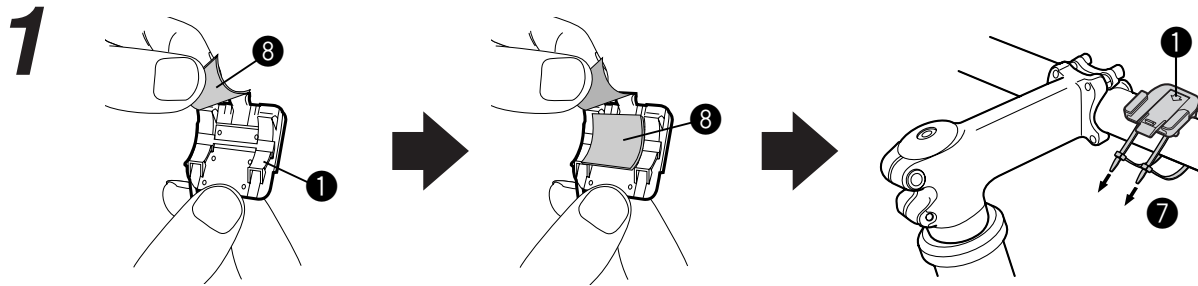

or

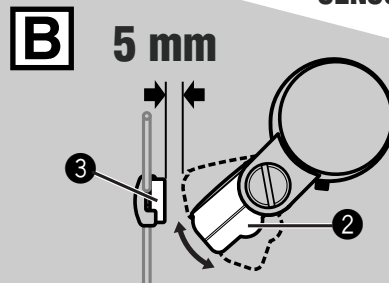
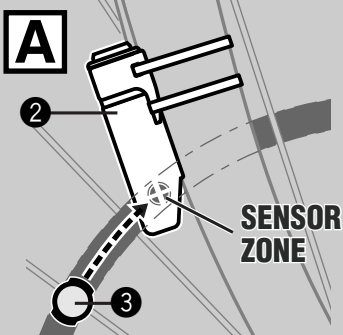
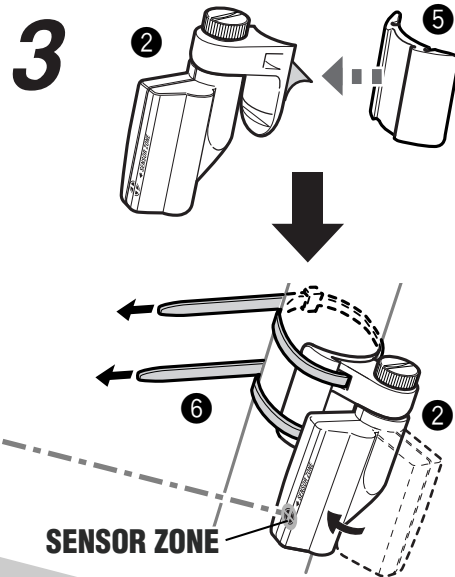
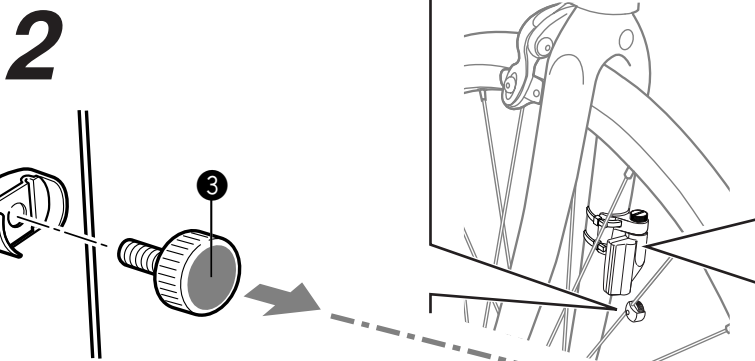

CZ

CC-MC100W MICRO Wireless

SET UP ↓ BEFORE USE ↓

1. All Clear

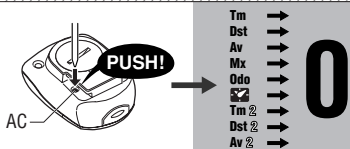

2. Select km/h or mph

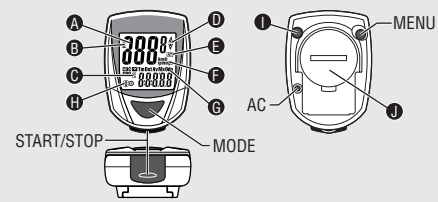
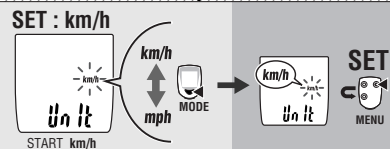

3. Wheel Circumference

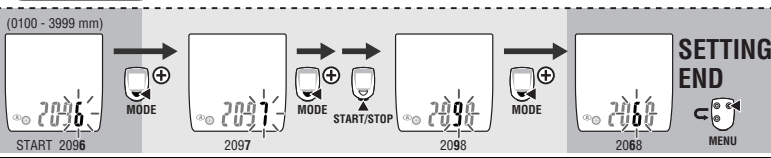
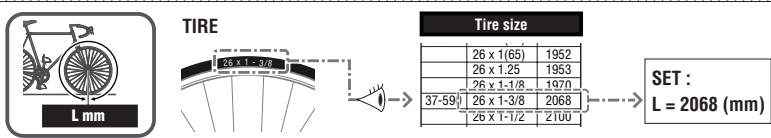

ETRTO	Tire size	L (mm)	ETRTO	Tire size	L (mm)	ETRTO	Tire size	L (mm)
	12 x 1.75	935		26 x 7/8	1920	32-630	27 x 1-1/4	2161
	14 x 1.50	1020	23-571	26 x 1 (59)	1913		27 x 1-3/8	2169
	14 x 1.75	1055		26 x 1 (65)	1952		650 x 35A	2090
	16 x 1.50	1185		26 x 1.25	1953		650 x 38A	2125
47-305	16 x 1.75	1195		26 x 1-1/8	1970	18-622	650 x 38B	2105
	18 x 1.50	1340	37-590	26 x 1-3/8	2068		700 x 18C	2070
	18 x 1.75	1350		26 x 1-1/2	2100		700 x 19C	2080
47-406	20 x 1.75	1515		26 x 1.40	2005		700 x 20C	2086
	20 x 1-3/8	1615	40-559	26 x 1.50	2010	20-622	700 x 20C	2096
	22 x 1-3/8	1770	47-559	26 x 1.75	2023	25-622	700 x 25C	2105
	22 x 1-1/2	1785	50-559	26 x 1.95	2050	28-622	700 x 28C	2136
	24 x 1	1753	54-559	26 x 2.00	2055		700 x 30C	2170
	24 x 3/4 Tubular	1785		26 x 2.10	2068	32-622	700 x 32C	2155
	24 x 1-1/8	1795	57-559	26 x 2.125	2070		700C Tubular	2130
	24 x 1-1/4	1905		26 x 2.35	2083	37-622	700 x 35C	2168
47-507	24 x 1.75	1890	57-559	26 x 3.00	2170		700 x 38C	2180
	24 x 2.00	1925		27 x 1	2145	40-522	700 x 40C	2200
	24 x 2.125	1965		27 x 1-1/8	2155			

OPERATION FLOW

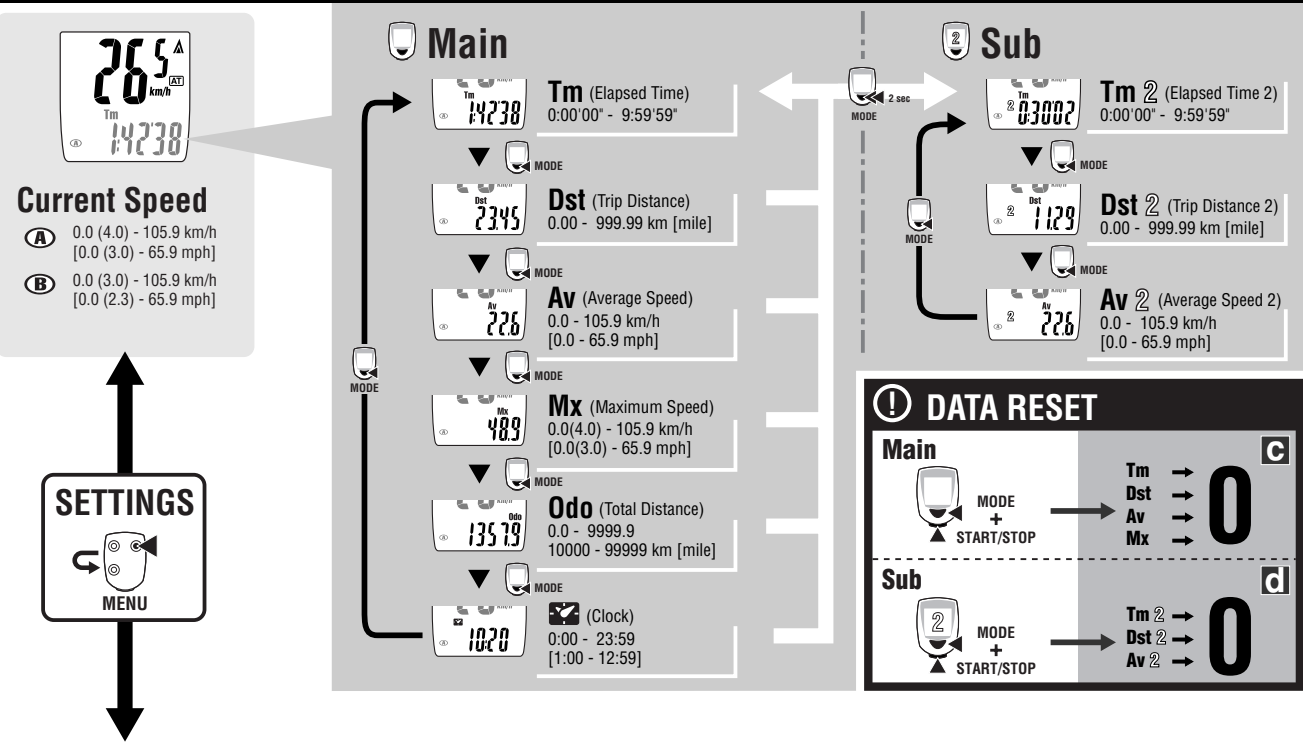

MENU FLOW (SETTINGS)

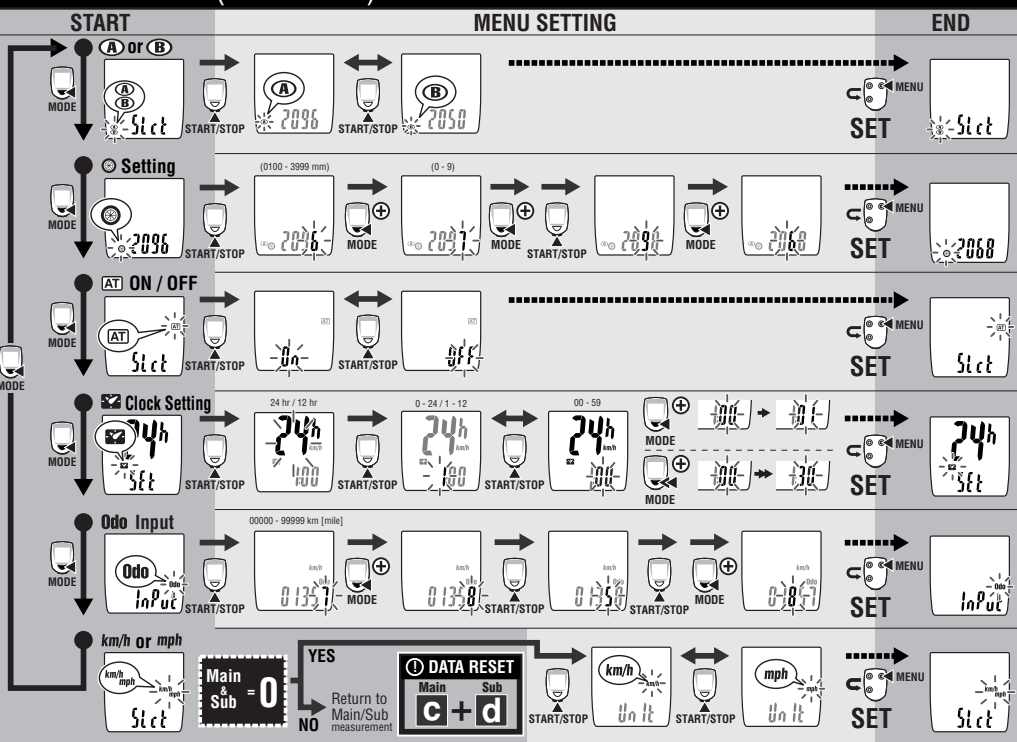

BATTERY

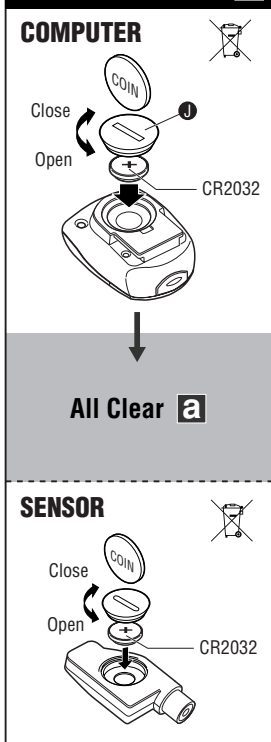

CZ

CC-MC100W MICRO Wireless

